

INSTRUCTION MANUAL

PORTABLE MAGNETIC DRILLING MACHINE

Read this manual carefully before operating your Nitto Kohki Portable Magnetic Drilling Machine. Keep this manual with your machine. All users of the Nitto Kohki Portable Magnetic Drilling Machine must read this manual.

ATRA ACE Model ARA-100A Professional Tool

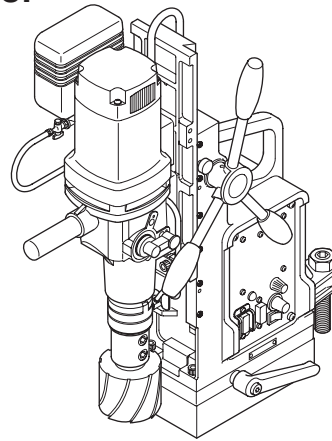

Specifications

Model		ARA-100A
Drill Motor	Power Source (Single Phase)	220-240 V AC 50/60 Hz
	Rated Power Consumption	1800 W
	Rated Current	8.2 A
	No-load Speed	110-210/330-660 min ⁻¹
Magnet	Power Consumption	80 W
	Holding power	17000N
	Dimensions	110 × 220mm
Weight	30kg (Cord and Sub handle are not included.)	
Short-Circuit Current Rating	5kA	
Cutter	Max. Plate Thickness	Hole Diameter
	35mm	17.5 to 40mm dia.
JETBROACH One-touch Type	50mm	17.5 to 50mm dia.
	75mm	17.5 to 50mm dia.
	75mm	50 to 100mm dia.
HI-BROACH One-touch Type	50mm	18 to 35mm dia.
TWIST DRILL	—	Max. 32mm dia.

Be sure to install a circuit breaker with a 15A rating on the power supply outlet before plugging this machine into the outlet.

Team lift when moving the machine.

The specifications and configurations contained in this document are subject to change without prior notice due to improvements we are making day in, day out.

Manufactured by :



NITTO KOHKI Co., Ltd.
2-9-4, Nakaikegami, Ota-ku,
Tokyo, 146-8555, Japan
Tel : (81)-3-3755-1111
Fax : (81)-3-3753-8791
E-mail : overseas@nitto-kohki.co.jp
URL : www.nitto-kohki.co.jp

Keep the manual handy – so you can use it whenever necessary.

Original Instruction

Thank you for purchasing **Nitto Kohki product.**

Before using this tool, please read this manual carefully so ensure proper, efficient operation.







This manual should be kept close at hand.

- **English** :Please ask your dealer or distributor for instruction manual in local language(s).
- **German** :Bitte fragen Sie Ihren Händler nach eine Betriebsanleitung in Landessprache.
- **French** :S'il vous plait, veuillez demandez à votre fournisseur de manuel instruction en langue locale.
- **Spanish** :Por favor, contacte con su distribuidor para el manual de instrucciones en español.
- **Portuguese** :Por favor pessa ao seo agente ou distribuidor o manual de instrucces ih linguagen local.
- **Italian** :Per Manuale Istruzioni in lingua locale Vi preghiamo di rivolgervi al rivenditore o distributore.
- **Dutch** :Vraag uw handelaar om een nederladstalige gebruiksaanwijzing.
- **Swedish** :Be er lokala Åtreförsäljare eller distributör om manualer på svenska.
- **Danish** :Venligst henvend Dem til den danske distributør for instructions manualer.
- **Polish** :Prosze pytac swojego dealera lub dystrybutora o instrukcje obsługi w języku localnym.
- **中文** :請向當地供應商或經銷商詢問中文使用說明書

CONTENTS



	page
GENERAL SAFETY RULES	2
POWER TOOL SAFETY	3
ABOUT YOUR NITTO PORTABLE MAGNETIC DRILLING MACHINE	4
1. APPLICATION	7
2. RECEIVING INSPECTION	7
3. PART NAMES	7
4. FUNCTION OF ELECTRIC CONTROL	8
5. MACHINE SETUP	8
6. MACHINE OPERATION	12
7. HOW TO USE TWIST DRILL	15
8. TROUBLESHOOTING	15
9. MAINTENANCE /SERVICE	16
10. OPTIONAL PARTS	17
11. ORDERING PARTS	19
12. ATRA ACE ARA-100A ASSEMBLY	20
13. ATRA ACE ARA-100A PARTS LIST	21
14. ATRA ACE ARA-100A MOTOR ASSEMBLY	22
15. ATRA ACE ARA-100A MOTOR PARTS LIST	23

PICTOGRAM

-  Warning: It might be dangerous to operate the machine if the instructions supplied are not followed.
-  Do not allow the main body or the power source to get wet as it will cause electric shock and leakage.
-  Using this tool improperly could result in serious injury. Read the instruction manual before using.
-  Always wear suitable eye protection.
-  Always wear suitable hearing protection.
-  Always wear respiratory protective equipment.

- Sound Pressure Level : Maximum 92dB(A)
Operating Condition : No load (Drill speed volume 100%, Drill speed change HIGH)
Measuring Method : According to clause 1.7.4.2 of Machinery Directive 2006/42/EC
- Sound Power Level : Maximum 103dB(A)
- Operating Temperature : 5°C ~ 40°C
- Max. operation altitude : 1000m
- Operating Humidity : Maximum 90% at 25°C
- Over-voltage Category : Category II according to IEC664-1
- Pollution Degree : Degree 3 according to IEC664-1
- Wiring Diagram No. : TZW0147
- Disposal of this product : When disposing of this product, please contact the distributor you purchased the product from.

The following Safety notations are used throughout the manual to highlight safety precautions for the user and for the machine.

 DANGER:	Indicates an imminently hazardous situation which, if not avoided by following the instructions given, will result in death or serious injury.
 WARNING:	Indicates a potentially hazardous situation which, if not avoided by following the instructions given, could result in death or serious injury.
 CAUTION:	Indicates a potentially hazardous situation which, if not avoided by following the instructions given, could result in injury or material damage.

Caution: Important precautions for machine or tool setup, operation and maintenance.

WARNING

Some dust created by power sanding, sawing, grinding, drilling, and other construction activities contains chemicals known [to the State of California] to cause cancer birth defects or other reproductive harm.

Some examples of these chemicals are:

- lead from lead-based paints,
- crystalline silica from bricks and cement and other masonry products, and
- arsenic and chromium from chemically-treated lumber.

Your risk from these exposures varies, depending on how often you do this type of work. To reduce your exposure to these chemicals: work in a well ventilated area, and work with approved safety equipment, such as those dust masks that are specially designed to filter out microscopic particles.

GENERAL SAFETY RULES

WARNING

TO OPERATORS

Always Wear Proper Clothing

- **Do not wear loose clothing. Loose clothing can become caught in the drilling machine.** This could cause severe injuries. Be careful that loose clothing does not come into contact with the machine.
- **Wear non-skid footwear.** If you lose your footing, you could contact moving portions of the machine. This could cause severe injuries. Always wear non-skid footwear and remain balanced when using the drilling machine.
- **Be careful of long hair.** Wear a hat or a hair net to contain long hair. Long hair can become caught in the drilling machine. This will cause severe injuries. Be careful that long hair does not come into contact with the drilling machine.

Always Wear Suitable Eye Protection

- **Always wear suitable eye protection.** The operation of your drilling machine will cause flying chips and particles. These will cause severe eye injuries. You must always wear suitable eye protection.
- **Not all glasses are suitable eye protection.** Wear only suitable eye protection that comply with ANSI standards. Not all of the lenses are shock resistant. Glasses for vision correction are not for eye protection. Select protective glasses suitable for the work.

Always Wear Suitable Hearing Protection

- **Always wear suitable hearing protection.** The operation of your drilling machine will cause big sound occurs. These will cause severe hearing loss

injuries. You must always wear suitable hearing protection.

Always Wear respiratory protective equipment

- **Always Wear respiratory protective equipment when working in an environment where dust particles are generated in operation.**

Maintain Good Posture

- **Always wear non-skid footwear and maintain good posture.** Do not use the drilling machine when you are tired. Fatigue or loss of balance could cause you to lose control of the machine. This could cause severe injuries. Always stay balanced. Always keep good posture. Stop using the machine if you are tired.

Never Touch the Cutting Tip

- **Never touch the moving parts or cutting tip.** Contact with the moving tip will cause severe injuries. Always keep all parts of your body away from the cutting tip. Always keep your hand and clothing away from the cutting tip.

ABOUT THE WORK AREA

Keep Work Area Clean

- **Always keep your work area clean.** Cluttered work areas cause accidents. Always keep clear of other objects.
- **Never use the magnetic drilling machine when it is wet.** Always use the drilling machine in a dry area. Do not use the drilling machine in the rain. If you use the machine when it is wet you can get electric shock. If you use the machine in the rain you can get an electric shock.
- **Always use the drilling machine in a well-lighted area.** Do not use the drilling machine in the dark.
- **Avoid all flammable materials.** Use of the drilling machine may cause a spark that could ignite a fire or an explosion. Never use the machine near any flammable material.
- **Keep away from children.** Always keep the drilling machine away from children. Do not operate drilling machine when children are present.

BEFORE OPERATION

Make sure that all parts are free from damage

- **Make sure that the drilling machine is in good operating condition.** Operating a damaged machine could result in severe injuries. If there is any damage to the machine, do not use the machine. If there is any damage to the machine, take it to an authorized Nitto dealer for repair.
- **Do not attempt service or repair of the drilling machine.** All service or repair should be done by an

authorized Nitto dealer.

Secure Your Work

- **Always secure your work piece.** Improperly mounted work can become loose. This can cause severe injuries. Always secure all work.
- **Do not attempt to hold any work piece with your hand.** Attempting to hold a work piece with your hand may cause severe injuries. Always use a vice or clamp to hold the work piece.
- **Always secure your drilling machine.** Improperly mounted drilling machine can come loose. This can cause severe injuries. Always secure the drilling machine.

Avoid Clutter

- **Always stay clear of other objects.** Cluttered work areas cause accidents. Always keep a clean work area and stay away from other objects.

Always Remove Spanner Wrenches and Adjustment Tools

- **Always remove spanner wrenches and adjustment tools after adjustments have been made to the drilling machine.**

Always Use a Cutter that is Appropriate for Your Work

- **Always use a Cutter that is appropriate for your work.** Avoid work that is beyond the capacity of your drilling machine. If the work exceeds the capacity of your drilling machine, this can cause accidents and severe injuries. Always use the drilling machine in accordance with its performance specifications.

SAFE HANDLING

- **Never leave the magnetic drilling machine unattended while it is running.** When the machine is unattended, disconnect the power source. Do not leave the work area until the machine comes to a complete stop.

HOW TO STORE YOUR MAGNETIC DRILLING MACHINE

- **Always store the machine off the cement floor and on flat surface with the machine unplugged.**
- **Always store the machine off the cement floor, flat surface and unplugged.**
- **Always store the machine in a dry area.**
- **Always keep the machine out of the reach of children.**

HOW TO CARRY YOUR MAGNETIC DRILLING MACHINE

- **Disconnect the power and turn off the machine whenever you carry the machine.**

MAINTENANCE

Do not take apart or modify your magnetic drilling machine.

- Do not attempt to disassemble or modify your magnetic drilling machine.
- Do not modify your magnetic drilling machine. Modifications can cause accident and severe injuries.
- All service and repairs must be performed by an authorized Nitto dealer. Any attempt to service or repair the machine yourself may result in an accident and severe injuries.

Check all Parts for Damage.

- Always inspect the magnetic drilling machine before use.
- Always check that the pilot pin and cutter are in good condition. Use of the machine with worn pilot pins or worn cutter can cause accidents and severe injuries.
- Inspect all cutters before you put them on the magnetic drilling machine.
- Do not operate the magnetic drilling machine with a damaged or worn cutter. Do not operate the machine with a damaged or worn pilot pin. Do not operate the machine with any damaged accessory. Operating the machine with any damaged part or accessory can cause accidents and severe injuries. If there is any damage to the magnetic drilling machine do not operate the machine. Take it to an authorized Nitto Dealer for repair.
- Always have the magnetic drilling machine repaired at an authorized Nitto dealer. Always take the magnetic drilling machine to an authorized Nitto dealer for service, repair and replacement parts. If you cannot locate an authorized Nitto dealer near you, please contact your sales representative.
- Always use Nitto genuine parts. The use of improper or non-Nitto parts can cause accidents and severe injuries.
To obtain genuine Nitto parts, contact your sales agent.
- Do not remove any nameplate from your magnetic drilling machine. Do not remove any labels from your magnetic drilling machine. If any label or nameplate is damaged contact your sales agent for a replacement.

POWER TOOL SAFETY

WARNING

- Always make sure that the machine is properly grounded. If the machine is not properly grounded, someone can get an electric shock.
- If you have any doubt about the grounding of

the magnetic drilling machine, contact a licensed electrician.

- Never connect the grounding conductor to a gas pipe. This will result in an explosion and severe injuries or death.
- Always check the grounding conductor. If you have any doubts about the grounding conductor contact a licensed electrician.
- Wiring connections to a grounding rod require the expertise of a licensed electrician. Do not attempt the wire connections yourself. Always contact a licensed electrician.
- Do not abuse the power cord. A damaged power cord can cause an electrocution. A damaged power cord can cause fires. Always inspect the cord. If the cord is damaged, do not use the magnetic drilling machine.
- Do not carry the machine by the cord. Do not pull the cord to disconnect it from a socket.
- The cord can become damaged from heat, contact with sharp objects or from being twisted. Always inspect the cord. Do not use the machine if the cord is damaged.
- Always use a ground fault circuit interrupter. The use of a ground fault circuit interrupter may be required by government regulations. The failure to use a ground fault circuit interrupter may result in electric shock.
- Avoid starting the magnetic drilling machine abruptly or unintentionally.
- Always make sure that the switch is turned off before connecting the power source.
- Always disconnect the power source and turn off the switch before setting up for work operations. Always disconnect the power and turn off the switch when inspecting work. Always disconnect the power and turn off the switch before attempting any maintenance. Failure to disconnect the power and turn off the switch during set up, inspection or maintenance can cause accidents and severe injuries.

ABOUT YOUR NITTO PORTABLE MAGNETIC DRILLING MACHINE

DANGER

Do not use your portable drilling machine on the ceiling.

- Use of the portable drilling machine on the ceiling is dangerous. The machine could fall. The falling machine could cause severe injuries or death. (Fig.1)

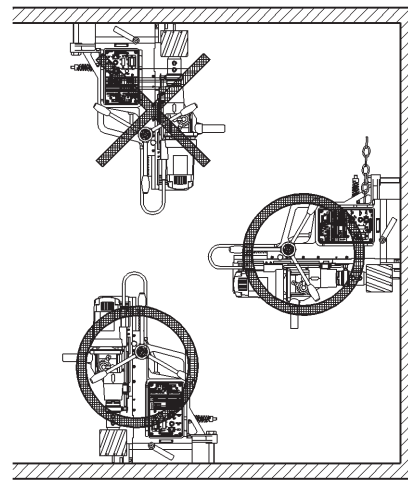

(Fig.1)

WARNING

Do not use the Magnet for more than five hours.

- More than five hours of uninterrupted operation may cause a fire. Five hours of uninterrupted operation generates extreme heat in the Magnet and permanently damage the internal coils. Do not touch the Magnet when the Magnet is hot. Touching it will cause a severe burn injury. When you are not using the Magnet, turn the switch to the OFF position and unplug the machine.

Do not use the Drill Motor for over 30 minutes.

- Uninterrupted operation of the Drill Motor for over 30 minutes generates heat. This heat can cause a fire. When you are not using the Drill Motor, turn the switch to the OFF position and unplug the machine.

Use only on magnetic materials.

- Your portable drilling machine cannot be used on non-magnetic materials, such as aluminum, stainless steel, copper or alloys. The Magnet will not adhere on non-magnetic materials. Attempting to use the Magnet on non-magnetic materials could cause an accident.

Use caution during wall operation.

- When using your portable magnetic drilling machine on a magnetic wall, always use caution.
- Never stand under the machine.
- * Never allow anyone to stand under the machine.
- * Never put any part of your body under the machine.
- * If the machine falls, it could result in severe injury or death.
- Always remove Cutting Oil from the Tank before using the machine on a wall. You must manually apply Cutting Oil to the cutting tool.

Always use a work piece that is at least 13 mm thick.

- The work piece must be at least 13 mm thick. If a

work piece is too thin, the magnetic power of your machine will decrease. This will cause the machine to move during operation. This could result in an accident. (Fig.2)

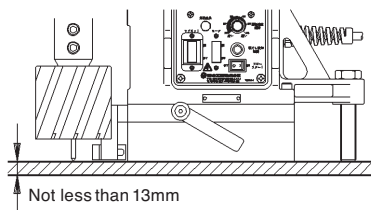

(Fig. 2)

Use an iron back-up plate.

- If the work piece is less than 13mm thick, you must use an iron back-up plate that is more than 10 mm in thickness. The surface area of the iron back-up plate must be greater than the surface area of the magnet. An appropriate back-up plate is necessary to boost the holding power of the Magnet.(Fig.3) Use of an inappropriate back-up plate can result in an accident. If the back-up plate is not thick enough or big enough, the machine will come loose during operation. This can result in an accident and severe injuries.

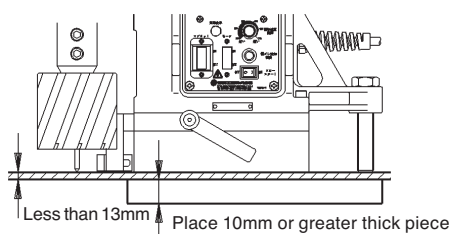

(Fig. 3)

Always keep surfaces clean.

- Always keep the Magnet surface clean. Always keep the work piece surface clean. If there are any foreign objects between the Magnet and the work piece surfaces, this will reduce magnetic power. This could cause the machine to move during operation. This can result in an accident. Keep all surfaces clean of rust, chips or other foreign material.

Do not place the machine over a hole.

- Do not attempt to position the Magnet over a hole. Attempting to straddle a hole will reduce the power of the Magnet. This will cause the work piece to come loose during operation and can cause an accident.

Always use a chain to secure the machine.

- If the machine falls, it can cause severe injuries. There is always a possibility that magnetic power can be lost or reduced because of a power failure. Magnetic power can be lost on rough surfaces. You must take precautions to prevent the machine from falling.
- This machine comes with a chain. The chain is to be used to fasten the machine to the work piece. If you

do not use the chain, it is possible that the machine may fall. (Fig.4)

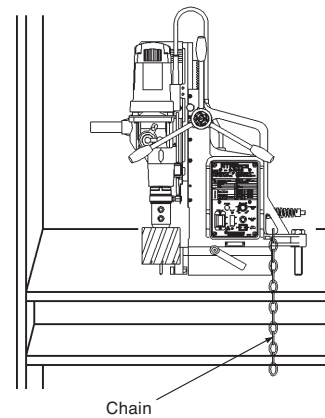

(Fig. 4)

- If use of the chain is not possible because of the size of the work piece, you must use another method of securing the machine. Use a Supporting Magnet Ass'y to prevent the machine from falling.
- The use of a Supporting Magnet Ass'y is shown below. (Fig.5)

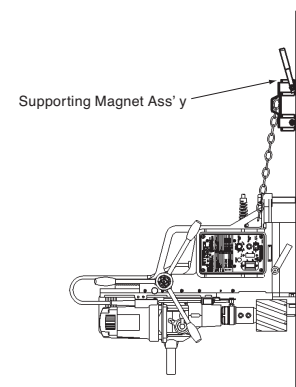

(Fig. 5)

Always set the Magnet in the proper position.

- Always set the Magnet parallel to the longitudinal direction of the material. Failure to set the Magnet in the proper position may result in reduced magnetic power. This can cause the machine to move in operation. This can cause an accident resulting in severe injuries.
- When using on H-section steel, as shown in the figure below, set the Magnet in a direction parallel to the longitudinal direction of the material. This will ensure that the Magnet is in the best position for magnetic attraction.(Fig.6)

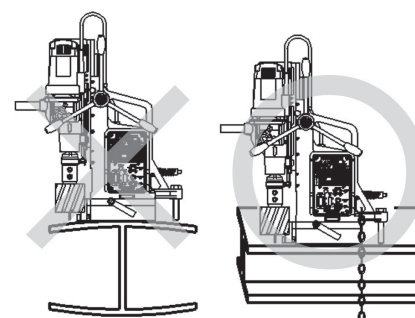

(Fig. 6)

- Poor magnetic power may result in damage to the cutter or damage to the work piece.

Be careful about chips.

- Keep your hands away from the cutting area at all times. During drilling, there will be chips. The chips are sharp. The chips are rotating with the cutter. Any contact with the chips can cause severe injuries.

Do not touch the slug.

- Do not touch the slug. The slug is very hot and sharp. It will cause severe burns. Make sure that no one touches the slug. Make sure that there is no one below the work area during operation. Hot slugs will fall. Hot slugs can cause severe burns, other severe injuries, or even death. Always wear protective equipment, including protective headgear, eye protection, hearing protection, and gloves. Do not allow any person without protective equipment to come near the machine.

Do not use your hands to remove chips.

- Chips have sharp edges. Use a screwdriver to remove chips. If you use your hands to remove chips, you can be injured, even if you are wearing gloves. Do not use your hands to remove chips under any circumstances.

The cutting edge is sharp.

- Always wear gloves when changing the cutter. The cutting edge is sharp. If you do not wear gloves, you will be cut. Attempting to change the cutter can result in severe injuries.

Do not use Cutting Oil for other purposes.

- Cutting Oil should be used only for drilling. Please refer to Section 5-7 of this manual for further warnings and instructions about Cutting Oil.
- Stop the work and inspect the machine when abnormal spark is observed with the carbon brushes of the drilling machine.

CAUTION

Always use a compatible Pilot Pin.

- The Pilot Pin must be compatible with the cutter. An improper Pilot Pin may result in an accident. See Section 5-3 to identify compatible Pilot Pins and cutters. The proper Pilot Pin to be used will vary, depending on the type of cutter, the diameter of the cutter, and the length of the cutter.

Do not use power that is generated by an engine-driven welder.

- The use of an engine-driven welder as a power source may cause your magnetic driven machine to malfunction, Power from an engine-driven welder can damage the electronic circuits in your portable drilling machine.

- Do not use an extension cord that is too thin. Do not use an extension cord that is too long. Do not use an extension cord that is wound on a drum. Do not share an extension cord with other motor-driven tools. These uses can cause voltage to drop and can reduce the holding power of the magnetic base, causing the machine to move during operation. This can decrease performance and may cause damage to the machine. (Fig.7)

Use a Proper extension cord.

Extension Cord	
Max length	Size (nominal cross-section area of the conductor)
10 m	Min 2.0 mm ² or more
20 m	Min 3.5 mm ² or more

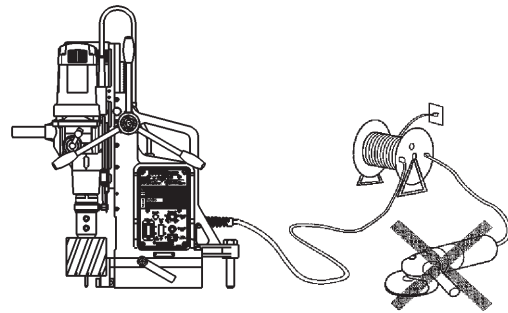

(Fig. 7)

Don't use this machine on the steel material being electrically welded.

- When the electric welder is not properly grounded, electricity will run through the Atra Ace machine via its Magnet and Power cord, causing possible failure or malfunctioning, which in turn may cause accident.

Don't force to feed cutter when drilling manually.

- Because the Hi-Broach and Jetbroach have rather thin cutting edges with less cutting pressure resistance as compared to twist drill, do not force to feed the cutter when drilling manually.

If you feed it with too much force, the cutter may break or end up with shorter life.

Lower the drill when not using to store the drilling machine.

- The main unit may turn over when the drill is kept in lifted position.

The color of LED changes according to the load of the drilling machine. Use the drilling machine when LED is green.

- LED turns green when load of the drilling machine is normal and turns red when excessive load is applied.

Excessive load is applied to the drilling machine when LED is turned red. Slow the feed speed to be able to drill with load in which lights only the green LED.

The output of motor decreases and LED turns red when excessive load is applied to the drilling machine. When the same load is further applied for approx. six seconds, the drilling machine will automatically stop and the green LED will blink.

- The output of the drilling machine decreases for protection when further load is applied in red LED. The drilling machine returns to normal operation when load is reduced before it completely stops by excessive load. When the drilling machine has stopped automatically, the drilling machine will only operate after turning the motor switch OFF and then turned back ON.

Team lift when moving the machine.

- The mass of the drilling machine is 30kg. Carry the machine with two people by holding the grip of the main unit and the side handle of the drilling machine.

1 APPLICATION

This is a portable drilling machine with a Magnet, geared to drill mild steel (mild steel or equivalent) using various cutters. The machine will be mounted on the work piece to be drilled with the Magnet securely fastening the machine to the work piece while drilling takes place.

2 RECEIVING INSPECTION

Upon unpacking, check to see that the shipment is complete without damage or oil leakage in transport. Should you find any damage or short-shipment, please contact sales agent through which you have purchased your machine or an authorized dealer near you for corrective actions.

Package Contents	Q'ty	Check
ATRA ACE	1set	
Holder MT03075 Side lock	1set	
Pilot Pin 12075	1	
Rod Handle	3	
Side Handle	1	
Hex. Socket Screw Key 2.5	1	
Hex. Socket Screw Key 5	1	
Hex. Socket Screw Key 6	1	
Hex. Socket Screw Key 8	1	
Spanner 7X8	1	
Drill Drift (see Fig.11)	1	
Chain	1	
Guard	1	
Instruction Manual	1	

3 PART NAMES

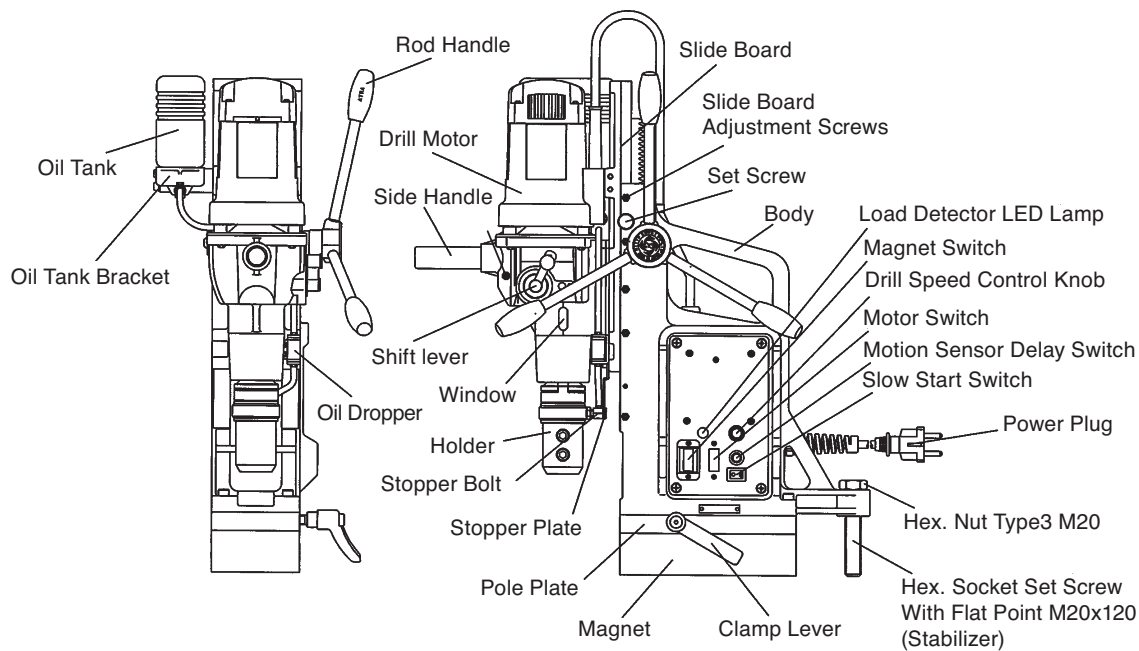

(Fig. 8)

4 FUNCTIONS OF ELECTRONIC CONTROL

4-1. Load detection function

Device to automatically operate functions described below when excessive load is applied in drilling.

Do not use the drilling machine with an engine generator as the power source or when the voltage of the power source is too high or low since the load detection function may not operate properly.

(1) Load indication function

The load condition of the drilling machine is indicated by LED. LED turns green when load of the drilling machine is normal and turns red when excessive load is applied.

(2) Automatic stop function

When load is further applied to the drilling machine with LED turned red, the output of motor drops and LED starts blinking quickly. When load is further applied for approx. six seconds in that condition, the drilling machine will stop automatically to protect the drilling machine and the green LED will blink.

To continue the work, turn the motor switch OFF, lift the cutter slightly in the hole, and then turn it ON.

The drilling machine will operate.

(3) Automatic restart function

When load is reduced before complete stop of the drilling machine by excessive load, LED switches from blinking in red to continuous green and returns to normal operation.

4-2. Drill speed control function

The speed of the drilling machine can be adjusted from 100 to 50% by turning the drill speed control knob to the right.

Use the control for fine adjustment of the drill speed when using materials difficult to machine, to prevent chattering of the cutter, to extend the service life of the cutter or other purposes.

4-3. Motion detection function

When excessive vibration or lateral motion of the magnet is observed during drilling, the drilling machine will stop and the red LED will blink.

To continue the work, turn the magnet switch OFF and ON again, lift the cutter slightly in the hole, and restart the operation.

4-4. Motion detection switching function

Prior to starting drilling operations while the drill motor is running, press the motion sensor delay switch to temporarily cancel the lateral motion detection function when adjusting the swivel base. The function will be

anceled for approx. eight seconds and the red and green LED blinks alternately, this allows the machine to drill properly after the base is adjusted.

4-5. Slow start function

The drilling machine operates in slow speed at the start of cut to reduce chattering during drilling. It will return to normal operation five seconds after load is detected.

Turn the slow start switch ON when using a cutter of $\phi 80\text{mm}$ or more.

Turn the switch OFF when using a cutter of below $\phi 80\text{mm}$.

4-6. Re-start Prevention

The re-start prevention function comes into play when power is restored after an outage during operation. The green LED will blink and the magnet will be activated, however, the drilling machine will not operate for safety.

Turn the motor switch to the OFF position and turn it back ON to operate the drilling machine and continue the work.

4-7. Magnet Interlock

When the Magnet fails, the drill motor will not start and the red LED lamp will blink. To repair a defective magnet, please contact the sales agent from whom you purchased your unit or an authorized dealer near you.

5 MACHINE SETUP

! WARNING

- When setting up machine, turn off the Magnet Switch and disconnect the power supply plug from power source.

5-1. Mounting Parts

(1) Rod Handle (three pieces)

Mount the Rod Handles on the Handle Boss.

(2) Side Handle

Mount the Side Handle on the Drill Motor.

(3) Oil Tank Bracket (Fig.9)

Mount the Oil Tank Bracket on the Slide Board.

(4) Stabilizer

Screw in Hex. Socket Set Screw with Flat Point M20x120 and Hex. Nut Type3 M20 to the rear part of the body.

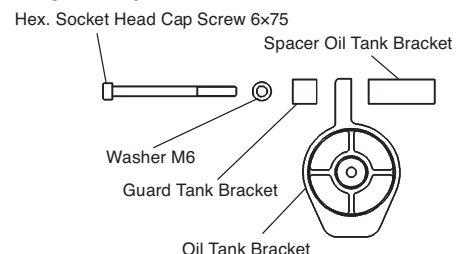

(Fig. 9)

5-2. Using Cutter

! CAUTION

- Use a holder appropriate for the cutter to use.
- Do not use worn or damaged cutter for better workability and safety.

(1) Holder MT03075 Side lock Ass'y (Standard accessory)

Holder exclusive for $\phi 50$ to $\phi 100\text{mm} \times 75\text{L}$ Jetbroach. Do not use for other cutters.

(2) Holder MT03075 One-touch Ass'y (Option)

Holder exclusive for Jetbroach one-touch and Hi-Broach one-touch. Do not use for other cutters.

5-3. Combination of Cutter and Pilot Pin

! CAUTION

- Do not use any other combinations than those shown in the compatibility table.

Use a Pilot Pin appropriate for the cutter. (Fig.10)

A Pilot Pin to be used varies depending on the cutter type, diameter, length (depth). A wrong combination of cutter and Pilot Pin would not allow slug to be ejected at the end of drilling and/or prevent Cutting Oil from reaching the cutting point, resulting in cutting tool damage.

Holder	Pilot Pin	Cutters
T809333 Holder MT03075 Side lock	T89A207 Pilot Pin 12075 112mm dia., 16mm dia., 192mm	Jetbroach 50 to 100mm dia. (75mm Depth)
T809279 Holder MT03075 One-touch	TJ12696 Pilot Pin 08025 (A1) 76mm, 8mm dia.	Hi-Broach One-touch Type 17.5 to 35mm dia. (25mm Depth)
	TJ15859 Pilot Pin 08035 (A2) 91mm, 8mm dia.	Jetbroach One-touch Type 17.5 to 40mm dia. (35mm Depth)
	TJ16019 Pilot Pin 08050 (A3) 112mm, 8mm dia.	Jetbroach One-touch Type 17.5 to 50mm dia. Hi-Broach One-touch Type 18 to 35mm dia. (50mm Depth)
	TJ17436 Pilot Pin 08075 (A4) 133mm, 8mm dia.	Jetbroach One-touch Type 17.5 to 50mm dia. (75mm Depth)

(Fig. 10)

5-4. Attachment and detachment of holder

! WARNING

- Turn the magnet switch OFF and unplug the power plug when replacing the holder.
- Do not use a holder that is not of a genuine product.
- Ensure the attachment of the holder. It may cause damage when holder is not attached properly.

! CAUTION

- Make sure that the Holder will fit in the Spindle of the Drill Motor.
- Keep the holder insertion area clean all the time. When waste such as cut chip is entered in the insertion area, remove it completely and then attach the holder.
- Make sure to prevent adhesion of oil to the holder insertion area and tapered shank when attaching the holder. Wipe the oil cleanly if oil is adhered.
- Pay attention not to drop the holder when attaching it.

(1) How to attach holder (Fig.11)

Engage the lugs on the holder to the notches in the spindle; rotate the oil ring to align the stopper bolt to the stopper plate, then insert the holder forcefully.

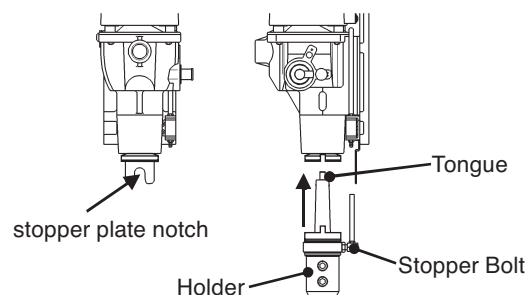

(Fig. 11)

(2) Detachment of holder (Fig.12)

Turn the drill so that the tongue at the holder head can be seen from the window of the drilling machine. Insert the drill drift through the window and hit the drill drift with a hammer to detach the holder.

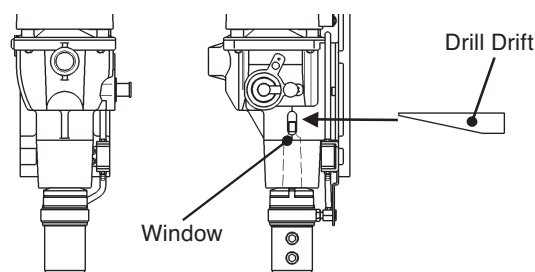

(Fig. 12)

5-5. Attachment and detachment of cutter

! WARNING

- Turn the magnet switch OFF and unplug the power plug when replacing the cutter.
- Do not use any combination of the pilot pin and cutter not indicated in the combination compatibility table.
- Wear gloves when replacing the cutter.

⚠ CAUTION

- Pay attention not to let cutting chips enter in the cutter insertion area.

If cutting chips have entered the cutter insertion area, remove the cutting chips completely before attaching the cutter.

- Make sure to remove the tip coating when using the Jetbroach.

When the Jetbroach is used without removing the tip coating, the cutting oil will not flow properly and may damage the cutter.

(1) Holder MT03075 Side lock Ass'y (Fig.13)

- 1) Turn the Rod Handle to lift the drill to the upper part of the main unit. (Fig.14)

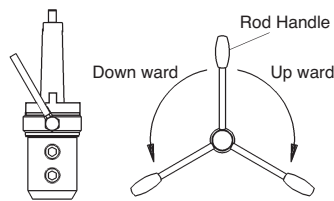

(Fig. 13) (Fig. 14)

- 2) Insert the Jetbroach to use in the pilot pin. (Fig.15)

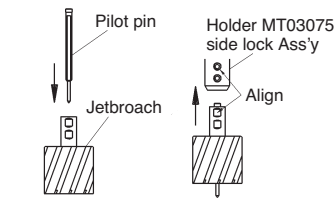

(Fig. 15) (Fig. 16)

- 3) Insert by matching the flat surface area of the Jetbroach with the holder screw. (Fig.16)

- 4) Securely tighten hexagon socket head stopper bolts with the supplied hexagonal wrench. Pay attention not to tighten hexagon socket head stopper bolts when they are in a slanted condition since hexagon socket head stopper bolts will bite into the holder and will not be able to remove them. (Fig.17)

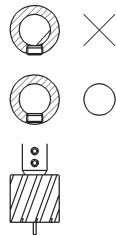

(Fig. 17)

(2) Holder MT03075 One-touch Ass'y (Fig.18)

- 1) Turn the Rod Handle to lift the drill to the upper part of the main unit. (Fig.19)

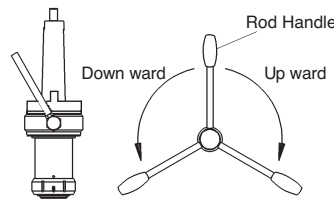

(Fig. 18) (Fig. 19)

- 2) Insert the pilot pin in the cutter according to the size of the cutter to use. (Fig.20)

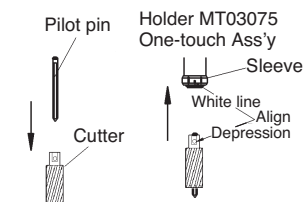

(Fig. 20) (Fig. 21)

- 3) Align the ball dent area of the cutter and white line of the sleeve and insert the cutter. (Fig.21)

- 4) When the cutter is inserted properly, the sleeve will rotate to the right and lock with a

clicking sound.

- 5) When the cutter cannot be inserted, rotate the sleeve to the left and then re-insert the cutter.

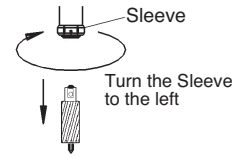

(Fig. 22)

- 6) The cutter can be detached by rotating the sleeve to the left. (Fig.22)

5-6. Setting the shift lever

⚠ WARNING

- Make sure to turn the motor switch OFF and wait until the drilling machine stops completely before switching the setting.

- Do not turn the motor ON and rotate the drill when switching the setting.

Switch the drill speed according the type and size of the cutter. (Fig.23)

Lift the plunger pin of the shift lever and turn the shift lever to switch the setting. (Fig.24)

If the shift lever gets caught at a certain point when turning, rotate the holder manually to the point where it does not get caught, and then turn the shift lever to the end.

Insert the plunger pin in the hole to secure the shift lever.

Refer to the table shown below for switching. Select the drill speed appropriate for the actual drilling since conditions differ depending on the material to drill.(Fig.25)

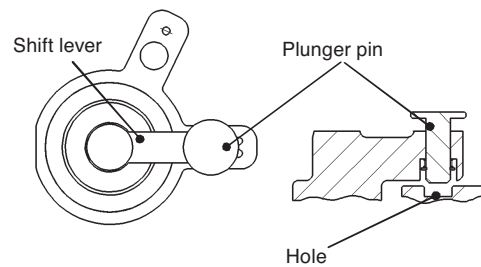

(Fig. 23)

(Fig. 24)

Drill Speed Change	
1	2
LOW	HIGH
JETBROACH 50 to 100 mm dia. (2" to 3-15/16")	JETBROACH One-touch 17.5 to 50 mm dia. (11/16" to 2")
HI-BROACH One-touch	
18 to 35 mm dia. (3/4" to 1-3/8")	
Twist Drill	
25 to 32 mm dia. (1" to 1-1/4")	Less than 25 mm dia. (1")

(Fig. 25)

5-7. Preparation of Cutting Oil

Cutting Oil Safety Precautions

⚠️ WARNING

(1) Use

- Use Cutting Oil for cutting purpose only. Don't use it for household purposes.

(2) Handling Precautions

- The Cutting Oil contains amine. Do not mix it up with rust inhibitor, etc. containing nitrite.
- Wear safety glasses for eye protection when handling Cutting Oil: eye injury may result if it gets into your eyes.
- Wear protective gloves for hand protection when handling Cutting Oil: skin injury may result if it comes into contact with your skin.
- Wear respirator when exposure to respiratory hazards with oil mist or vapor is anticipated. Inhalation of oil mist or vapor may make you feel sick.
- When diluting Cutting Oil, follow the instructions per the Operation Manual.
- Keep Cutting Oil out of reach of children.
- Don't drink Cutting Oil.

(3) First Aid

- If Cutting Oil gets into your eyes, immediately open your eyelids with your fingers and wash your eyes with plenty of water for at least 15 minutes. If your eyes feel irritated, consult with a medical doctor and follow his/her instructions
- If Cutting Oil comes into contact with your skin, immediately wash it away with plenty of water and soap. Take off contaminated clothes. Clean the clothes if you need to wear it again. If your skin feels irritated, consult with a medical doctor for medical instructions.
- If someone inhales oil mist or vapor, immediately take him/her to an area where fresh air is abundant and wrap up his/her body with a blanket, etc. to keep body temperature. Have him/her take a rest and consult with a medical doctor for medical instructions.
- If someone drinks Cutting Oil, immediately make him/her drink plenty of water and vomit it. Consult with a medical doctor for medical instructions. When unconscious, do not pour water into his/her mouth nor induce him/her to vomit.

(4) Instructions in Case of Fire

- If fire breaks out in the vicinity, wear PPE (personal protective equipment) and use foam, powder or CO₂ fire extinguisher to put the fire out from the windward.

(5) Storage

- When storing Cutting Oil after use, put into a container with a tight sealing lid to prevent contamination from dust or moisture.

- Avoid direct sunlight, rainwater or the like and store Cutting Oil in a dim cool area.

(6) Disposal

- For disposal of concentrate solution and used fluid, request a waste-disposal company to dispose them as industrial waste in accordance with the local laws and regulations.
- Treat flushing water through pH adjustment, condensation/sedimentation, activated sludge process, activated carbon adsorption, etc., and discharge it in accordance with the regulations of your local municipal bylaw.
- Residual dross will remain in an emptied container: be careful when handling an empty container.

(7) Others

- When Cutting Oil is poured into another container for use, post chemical and label information at the site where it is kept. At the same time, keep the Operation Manual handy so that it can be referred to whenever necessary.
- For further details, contact us for product safety data sheet.
- All the information and descriptions that have been provided are based on the currently available documents and information, which may be revised upon our new recognition and/or discovery.
- The precautions provided apply to regular handling. If special handling method is used, take safety measures that are suitable for your applications and usage.
- The information contained herein is for your reference purpose only, to which we make no warranty of any kind and for which we shall not be held responsible.

Preparation of Cutting Oil

- (1) Remove the oil tank from the oil tank bracket.
- (2) Remove the cap of the oil tank and fill with cutting oil.
- (3) Tighten the cap of the oil tank and turn the oil tank up-side-down to insert in the oil tank bracket. (Fig.26)

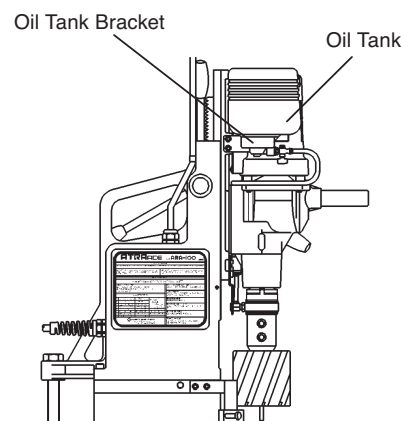

(Fig. 26)

5-8. Connecting the Power Supply Plug to Power Source

Turn the power switch OFF before plugging the power plug.

Always use appropriate voltage for the power source. Pay attention to voltage drop when using an extension cord.

6 MACHINE OPERATION

! WARNING

- Do not wear gloves. Wearing of gloves may cause the hand to be caught in the rotating drill or cutting chips.
- Always Wear Safety Glasses.
- Always Wear Hearing Protection.
- Wear respiratory protective equipment.

! CAUTION

- Do not use hard material such as a screwdriver, to operate the Motor Switch. This may damage the panel and switch, which would lead to machine failure.

6-1. Start and Stop

Motor switch will not operate and the drill will not rotate unless the magnet switch is turned ON.

(1)Start (Fig.27)

· Magnet ON

When the magnet switch is turned ON, the load indication LED will turn green and the magnet will be activated.

· Drill Motor ON

Turn the motor switch ON. The drill will start to rotate.

(2)Stop (Fig.28)

· Drill Motor OFF

The drill will stop when the motor switch is turned OFF.

· Magnet OFF

When the magnet switch is turned OFF, the load indication LED will turn off and the magnet will be deactivated.

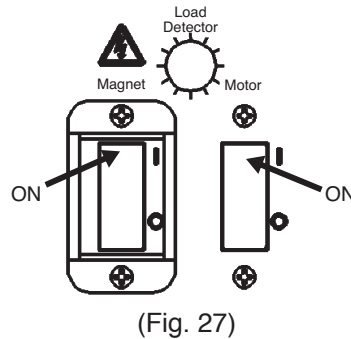

(Fig. 27)

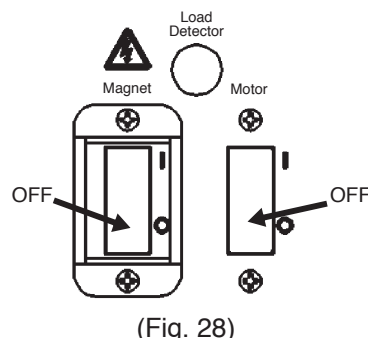

(Fig. 28)

6-2. When drilling a large hole

! CAUTION

- Drill slowly when drilling a large hole.

Turn the slow start switch ON when using a cutter of $\phi 80\text{mm}$ or more. Turn the switch OFF when using cutters below $\phi 80\text{mm}$.

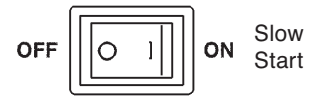

(Fig. 29)

Operate in a slow speed at start of the drilling to reduce the chattering and return to normal operation five seconds after the load detection.

6-3. Adjustment of drill speed

! CAUTION

- Reducing the speed of the Drill Motor by using the Drill Speed Control will also reduce the cooling efficiency of the Drill Motor, so do not use continuously.

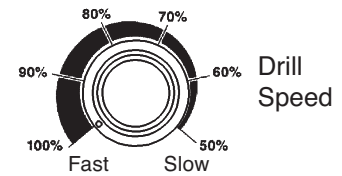

(Fig. 30)

Continuous use may lead to early damage of the Drill Motor.

- Drill a hole slowly since the drill speed control will reduce the drill speed and power.

The drill speed of the drilling machine can be adjusted from 100 to 50% by turning the drill speed control knob to the right.

Adjust the drill speed according to the machining material and condition of the cutter. (Fig.30)

6-4. Fine adjustment of drilling position(Fig.31)

! WARNING

- Securely tighten the clamp lever.

The main unit can be minutely adjusted to right & left and front & rear by turning the clamp lever counterclockwise.

Precisely adjust the drilling position when it is not properly aligned with a punch mark.

After the adjustment, turn the clamp lever clockwise and securely tighten it.

*The clamp lever can be attached on either right or left side.

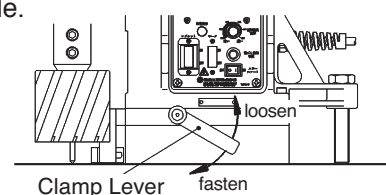

(Fig. 31)

6-5. Drilling Oblong Hole

⚠ CAUTION

- **Always drill oblong hole slowly.**
Drill oblong hole in the order of ①, ②, ③. For the steps ② and ③, take care so that the cutter may not be fed into the work piece with too much force. Spacing between each step of drilling operations should be so arranged that the Pilot Pin will always hit the material yet to be machined. (Fig.32)

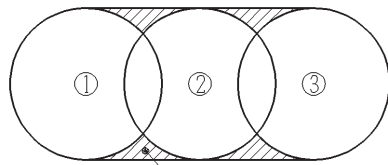

File away any remaining excesses

(Fig. 32)

6-6. Drill Stacked Plates

⚠ CAUTION

- **When drilling stacked plates, fix the steel plates so that the gap between the plates must be less than or equal to 1mm.**
- **Use special one-touch Jetbroach Cutters exclusively designed for stacked plates.**
Drill slowly when drilling stacked plates. Securely fix stacked plates together.

6-7. Drilling Procedure

⚠ CAUTION

(1)Punch Mark

A large punch mark should always be stamped quite vertical to the work piece. Be careful to get the precise position for the punch mark since it serves as the drilling center guide. (Fig. 33)

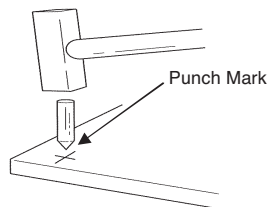

(Fig. 33)

(2)Aligning with Punch Mark.

Turn the Rod Handle to slightly lower the cutter and align the tip of Pilot Pin to the punch mark. (Fig.34)

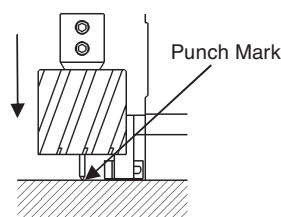

(Fig. 34)

(3)Magnet ON

⚠ WARNING

- **There is a risk of the main unit to sway when an abnormal object is caught between the attaching surface of the magnet and the work piece.**

The magnetic force will be weak when there is a gap between the attaching surface of the magnet and the work piece.

Make sure to keep it clean by preventing entry of abnormal objects such as cutting chips and checking that no uneven surface or rust is observed on the surface.

- **Check that the magnet is attached by the magnetic force.**

Turn on the Magnet Switch.

The Load Detector Lamp turns green and the magnet will be attached by the magnetic force.(Fig.35)

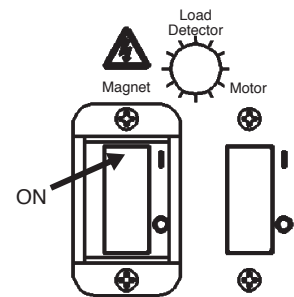

(Fig. 35)

(4)Adjustment of stabilizer

⚠ WARNING

- **Set the stabilizer properly.**

The stabilizer is used for the magnetic force to be applied effectively. Turn the magnet ON and then adjust the stabilizer to be closely attached to the work piece. Pay attention that the magnet is not lifted by excessively extending the stabilizer. (Fig.36)

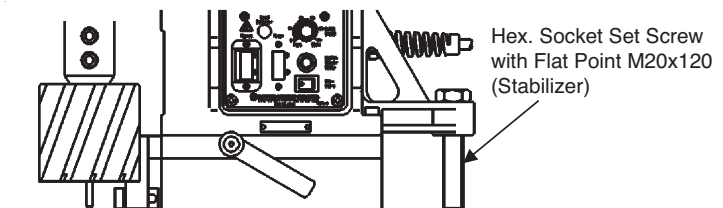

(Fig. 36)

(5)Mounting the Guard

Mounting the Guard as shown. (Fig.37)

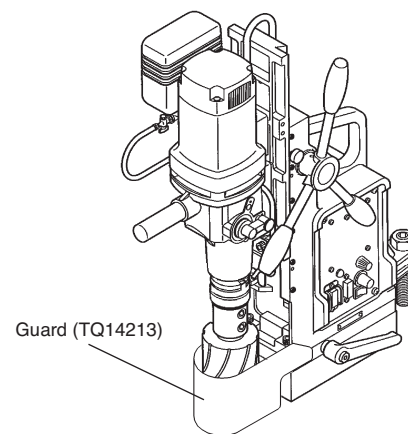

(Fig. 37)

(6) Adjustment of cutting oil

! CAUTION

- For feeding of the cutting oil, check the flow rate with the oil dropper before start drilling.
- Securely insert the oil tank in the oil tank bracket.

The pilot pin will be pushed up and the cutting oil will start to flow by turning the P Valve, turning the handle bar and lowering the drill. Adjust the flow rate referring to the oil dropper.

Tighten the P Valve when the work is completed. (Fig.38)

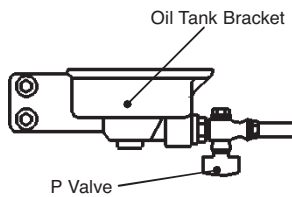

(Fig. 38)

(7) Drill Motor ON

! WARNING

- Don't touch any rotating parts. Press the Drill Motor ON Switch to activate the Drill Motor. (Fig.39)

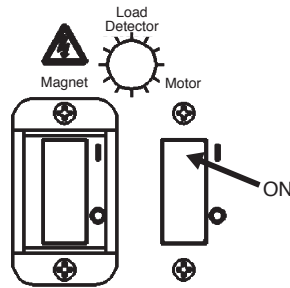

(Fig. 39)

(8) Drilling

(8-1) Drilling

Turn the Feed Handle downward to start drilling. For the first 2 – 3 mm of the drilling, slowly feed the drill motor.

(8-2) Final stage of drilling

! CAUTION

When drilling a hole in an angle, channel or H-section steel, etc., cutter may be damaged when it comes to the slanted part of the work piece on the final cutting stage. Feed slowly in its start and finish cutting. (Fig.40)

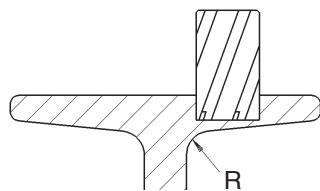

(Fig. 40)

(9) Finish drilling the hole

! WARNING

- Beware of ejecting slug when finish with the hole. Never touch the slug with bare hands since

it is hot and sharp.

After complete drilling, turn the Feed Handle to uplift the cutter and press the stop switch.

When the drill motor stops, immediately turn off the power switch. Continuous current flow through the magnet, while it is ON, could shorten the service life of the magnet.

(10) Removing Slug

! WARNING

Do not start the next drilling with a slug remaining on the cutter.

The tool has automatic slug discharge system. But when the slug would not come out by turning the feed handle to lift up the cutter, do not try to turn the handle forcefully. This will result in machine or cutter damage. Upon drilling complete, slug will be ejected automatically by the spring-operated pilot pin.

Should the slug left choked inside the cutter, turn the handle to lift up the cutter to eject the slug forcefully. When even turning the handle with the same force as in the feed for cutting a hole, you cannot eject the slug, do not turn the handle forcefully any more. Remove the slug from inside the cutter by tapping the collar of the slug with a needle stick or alike.

(Fig. 41)

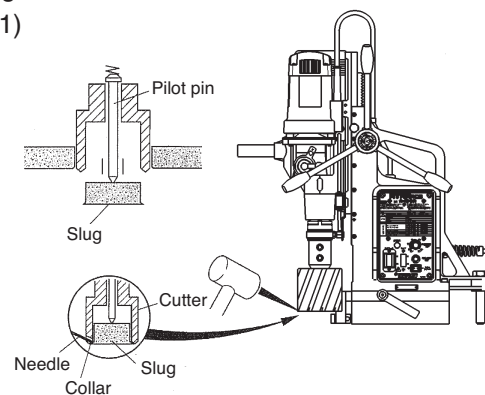

(Fig. 41)

6-8. Position Change of Rod Handles

- The Rod Handle can be attached on either right or left of the machine.

However, the Oil Tank Bracket must be attached on the opposite side of the Rod Handle.

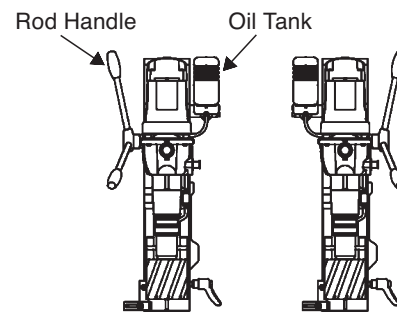

(Fig. 42)

7 HOW TO USE TWIST DRILL

7-1. Attachment of twist drill

WARNING

- When attaching the twist drill, turn the magnet switch OFF and unplug the power plug.
- Do not use a worn twist drill.
- Do not use a twist drill that is not properly reground.
- Wear gloves when replacing the twist drill.

CAUTION

- The shank of the drilling machine is using Morse taper No.3. Use a sleeve according to the size of the Morse taper when using a twist drill with Morse taper other than Morse taper No.3.
- Securely set the twist drill.
- When using the straight drill of $\phi 13\text{mm}$ or less, use it by combining a chuck arbor of a commercially available Morse taper No.3 and a drill chuck.

7-2. How to drill a hole

WARNING

- Make sure to have a pilot hole when drilling a hole of $\phi 20\text{mm}$ or more.

- The pressing force tends to be stronger when drilling with a twist drill than a circular cutter. Pay attention not to have the magnet lifted by pressing the work piece too hard.

CAUTION

- Oil tank cannot be used when using the twist drill. Feed cutting oil using a jet oiler, etc. from outside the twist drill.
- Refer to 6 MACHINE OPERATION for the drilling method.

7-3. How to temporarily cancel the lateral motion detection function

CAUTION

- Do not use this function when using a Jet-Broach or Hi-Broach.
- The lateral motion detection function may be activated and stop the drilling machine when the drill is rotated to loosen the clamp lever to align the center.
- To temporarily cancel the lateral motion detection function, press the motion sensor delay switch when the drilling machine is operating. The function will be canceled for approx. eight seconds and the red and green LED blinks alternately.

8 TROUBLESHOOTING

WARNING

- Never attempt to repair machine yourself: injury or damage to equipment may result.
- Please feel free to consult the sales agent through which you have purchase your machine or an authorized dealer, when the following symptoms appear or when you have any questions about our products.

The machine has electronic control. Be sure to turn off all the switches, raise up the electric drill, and then check the machine, when the operator come across to the following situations such as.

Problem	Causes	Solutions
Switch lamp does not come on when the power switch is turned on.	Power plug is not properly connected to receptacle.	Connect power plug properly to receptacle.
The drill motor would not start and LED lamp brinks in red when the motor switch is turned on.	The magnet is not activated.	Request for repair to check the continuity to the magnet.
The drill does not rotate even when the motor switch is turned ON.	The drilling machine or control circuit is damaged.	Request for repair.
	Carbon brush is worn out.	Replace the carbon brush.
The drill motor stops during drilling. (The magnet stops working and the power ON lamp is off.)	Power failure or plug was pulled out of power supply.	Restore power or insert power plug back in, then set the start switch on again.
The magnet is moved laterally, the drilling machine completely stops by the function of the lateral motion detection function and the red LED is blinking quickly.	Work piece too thin.	Use back-up plate: thickness 10 mm or more.
	Chips under Magnet base.	Clean it up.
	Worn cutting edge.	Reground or replace with new one.
	Effective magnetic force too weak.	Ask for repair.
No cutting oil or insufficient cutting oil flow.	The valve is closed.	Open the valve.
	Coolant tank is empty.	Refill cutting oil into the tank.

9 MAINTENANCE/SERVICE

WARNING

- Always turn off the switch and unplug the machine before attempting any maintenance. Failure to disconnect the power and turn off the switch during set up, inspection or maintenance can cause accidents and severe injuries.
- Check to see periodically that mounting screws are tight. If you find them loose, retighten.

9-1. Keep the drill motor at the lifted up position

- Keep the drill motor at the lifted up position while not in use, or for the purpose of safety, when you do not use the machine even for a while if it has a cutter mounted. The pilot pin and/or cutter may have the chance to be damaged if you keep the cutter at the low position while carrying around.

9-2. Periodic application of grease to sliding surface

Apply grease periodically to the sliding surface of the main unit and the slide board.

9-3. Adjustment of loose Slide Board

CAUTION

- When tightening the adjustment screw to adjust the looseness of the slide board, check that the slide board is at the position of the slide board adjustment screw.

The drilling accuracy will deteriorate and the service life of the cutter will be significantly short when looseness exists at the main unit and the slide board. When looseness is observed, adjust it by evenly tightening six slide board adjustment screws on the side of the main unit to a degree in which the drilling machine does not go down by its weight.

9-4. Keep the Tip of Pilot Pin Sharp

When the tip of pilot pin gets dull, it sometimes fails to seat properly in punched hole, and results inaccurate hole position. See that the tip is sharp enough from time to time. If you find otherwise, regrind with care or replace as required. Grinding with too much force makes the tip rather dull or softens the pin material to such a degree that it is no longer usable.

(Fig. 43)

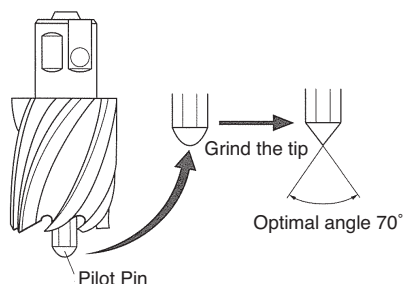

(Fig. 43)

9-5. Recovery Measures When Pilot Pin Gets Jammed

To replace the cutter, dismount the cutter from drill and remove the pilot pin from the old cutter and insert it into the new replacement cutter. The pilot pin serves as the guide for the cutter centering. However there are cases the pin would not come off easily because cutting chips in the clearance between the cutter and pin, cause jamming. In such, tap the tip of the pilot pin with a WOODEN hammer or alike to push it out.

9-6. Cutter Regrinding

When you need to regrind our cutters, please contact sales agent through which you have purchased or an authorized dealer near you.

9-7. Carbon Brushes Inspection and Replacement

CAUTION

- Unplug the machine.
- Replace two carbon brushes at the same time.

Periodically check the wear condition of the carbon brush.

A cut-off brush is used for the carbon brush. The electric current will automatically shut down when the carbon brush is worn out.

Replace to new carbon brushes following the procedure below when the electric current is shutdown. Pay attention that the pig tail will not be caught to the brush holder. (Fig. 44)

- (1) Remove the tapping screw and remove the end cap.
- (2) Remove the spiral spring, take out the worn carbon brushes, set new carbon brushes and attach the end cap. Set the carbon brushes with the pig tail facing upward.
- (3) After the replacement, operate the drilling machine for 10 minutes without any load to break in the carbon brushes.

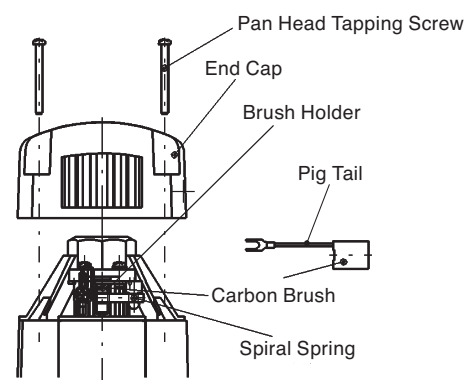

(Fig. 44)

10 OPTIONAL PARTS

10-1. Nitto-Brand Cutting Oil

CAUTION

Use Nitto-brand Cutting Oil for Atra-Ace.

Part No.	Part Name
TB01507	Cutting Oil 2 ℓ (Light Blue)

10-2. Supporting Magnet Ass'y (Fig.5)

Part No.	Part Name
TB04374	Supporting Magnet Ass'y

10-3. Holder MT03075 One-touch Ass'y

Part No.	Part Name
TB09727	Holder MT03075 One-touch Ass'y

10-4. Pilot Pin

Part No.	Part Name	Max. Plate Thickness	Applicable Cutter
TJ12696	Pilot Pin 08025 (A1)	25mm	Hi-Broach One-Touch 18 to 35 mm dia.
TJ15859	Pilot Pin 08035 (A2)	35mm	Jetbroach One-Touch 17.5 to 40 mm dia.
TJ16019	Pilot Pin 08050 (A3)	50mm	Jetbroach One-Touch 17.5 to 50 mm dia. Hi-Broach One-Touch 18 to 35 mm dia.
TJ17436	Pilot Pin 08075 (A4)	75mm	Jetbroach One-Touch 17.5 to 50 mm dia.
TA9A207	Pilot Pin 12075	75mm	Jetbroach 50 to 100 mm dia.

10-5. Chip Breaker Ass'y

Part No.	Part Name
TB09276	Chip Breaker Ass'y

Preparation of Chip Breaker

CAUTION

When setting the chip breaker, see that the tip of blade may not come into contact with the cutting tool.

Chip Breaker shreds cutting chips generated in the drilling into small pieces and facilitates chips smooth discharging.

(1) Mount cutter

Loosen the Hex. Socket Head Cap Screw, and pull the blade away in the direction as shown by the arrow until it would no longer move. And then, mount a cutter. (Fig.45)

(2) Set the blade

Set the blade so that the cutter and the blade will have a clearance of 0.5 – 0.8mm and fasten it securely to the blade stay with Hex. Socket Head Cap Screw 8x20. (Fig46)

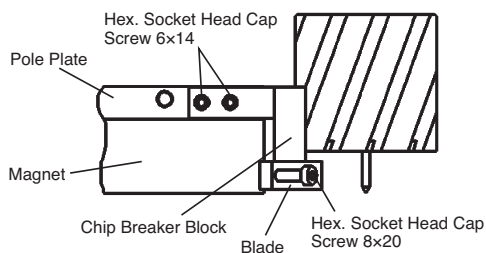

(Fig. 45)

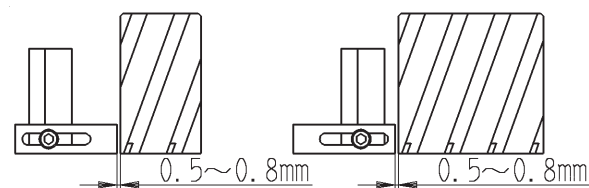

(Fig. 46)

10-6. Cutter

(1) Jetbroach One-touch Type 35mm Depth

Pilot Pin 08035(A2)

Part No.	Diameter x Depth(mm)	Part No.	Diameter x Depth(mm)	Part No.	Diameter x Depth(mm)
TK00301	17.5 x 35	TK00313	23.5 x 35	TK00324	32 x 35
TK00302	18 x 35	TK00314	24 x 35	TK00325	33 x 35
TK00304	19 x 35	TK00315	24.5 x 35	TK00326	34 x 35
TK00305	19.5 x 35	TK00316	25 x 35	TK00328	35 x 35
TK00306	20 x 35	TK00317	26 x 35	TK00602	36 x 35
TK00307	20.5 x 35	TK00318	26.5 x 35	TK00603	37 x 35
TK00308	21 x 35	TK00319	27 x 35	TK00604	38 x 35
TK00309	21.5 x 35	TK00320	28 x 35	TK00605	39 x 35
TK00310	22 x 35	TK00321	29 x 35	TK00606	40 x 35
TK00311	22.5 x 35	TK00322	30 x 35		
TK00312	23 x 35	TK00323	31 x 35		

(2) Jetbroach One-touch Type 50mm Depth

Pilot Pin 08050(A3)

PartNo.	DiameterxDepth(mm)	PartNo.	DiameterxDepth(mm)	PartNo.	DiameterxDepth(mm)
TK00380	17.5 x 50	TK00394	25 x 50	TK00408	38 x 50
TK00381	18 x 50	TK00395	26 x 50	TK00409	39 x 50
TK00382	19 x 50	TK00396	26.5 x 50	TK00410	40 x 50
TK00383	19.5 x 50	TK00397	27 x 50	TK00411	41 x 50
TK00384	20 x 50	TK00398	28 x 50	TK00412	42 x 50
TK00385	20.5 x 50	TK00399	29 x 50	TK00413	43 x 50
TK00386	21 x 50	TK00400	30 x 50	TK00414	44 x 50
TK00387	21.5 x 50	TK00401	31 x 50	TK00415	45 x 50
TK00388	22 x 50	TK00402	32 x 50	TK00416	46 x 50
TK00389	22.5 x 50	TK00403	33 x 50	TK00417	47 x 50
TK00390	23 x 50	TK00404	34 x 50	TK00418	48 x 50
TK00391	23.5 x 50	TK00405	35 x 50	TK00419	49 x 50
TK00392	24 x 50	TK00406	36 x 50	TK00420	50 x 50
TK00393	24.5 x 50	TK00407	37 x 50		

(3) Jetbroach One-touch Type 75mmDepth

Pilot Pin 08075(A4)

Part No.	Diameter x Depth(mm)	Part No.	Diameter x Depth(mm)	Part No.	Diameter x Depth(mm)
TK01036	17.5 x 75	TK01014	29 x 75	TK01026	41 x 75
TK01003	18 x 75	TK01015	30 x 75	TK01027	42 x 75
TK01004	19 x 75	TK01016	31 x 75	TK01028	43 x 75
TK01005	20 x 75	TK01017	32 x 75	TK01029	44 x 75
TK01006	21 x 75	TK01018	33 x 75	TK01030	45 x 75
TK01007	22 x 57	TK01019	34 x 75	TK01031	46 x 75
TK01008	23 x 75	TK01020	35 x 75	TK01032	47 x 75
TK01009	24 x 75	TK01021	36 x 75	TK01033	48 x 75
TK01010	25 x 75	TK01022	37 x 75	TK01034	49 x 75
TK01011	26 x 75	TK01023	38 x 75	TK01035	50 x 75
TK01012	27 x 75	TK01024	39 x 75		
TK01013	28 x 75	TK01025	40 x 75		

(4) Jetbroach Side lock Type 75mm Depth**Pilot Pin 12075**

Part No.	Diameter × Depth(mm)	Part No.	Diameter × Depth(mm)	Part No.	Diameter × Depth(mm)
TJ17709	50 × 75	TJ16667	67 × 75	TJ16684	84 × 75
TJ16651	51 × 75	TJ16668	68 × 75	TJ16685	85 × 75
TJ16652	52 × 75	TJ16669	69 × 75	TJ16686	86 × 75
TJ16653	53 × 75	TJ16670	70 × 75	TJ16687	87 × 75
TJ16654	54 × 75	TJ16671	71 × 75	TJ16688	88 × 75
TJ16655	55 × 75	TJ16672	72 × 75	TJ16689	89 × 75
TJ16656	56 × 75	TJ16673	73 × 75	TJ16690	90 × 75
TJ16657	57 × 75	TJ16674	74 × 75	TJ16691	91 × 75
TJ16658	58 × 75	TJ16675	75 × 75	TJ16692	92 × 75
TJ16659	59 × 75	TJ16676	76 × 75	TJ16693	93 × 75
TJ16660	60 × 75	TJ16677	77 × 75	TJ16694	94 × 75
TJ16661	61 × 75	TJ16678	78 × 75	TJ16695	95 × 75
TJ16662	62 × 75	TJ16679	79 × 75	TJ16696	96 × 75
TJ16663	63 × 75	TJ16680	80 × 75	TJ16697	97 × 75
TJ16664	64 × 75	TJ16681	81 × 75	TJ16698	98 × 75
TJ16665	65 × 75	TJ16682	82 × 75	TJ16699	99 × 75
TJ16666	66 × 75	TJ16683	83 × 75	TJ16700	100 × 75

(5) For Piling board Jetbroach One-touch Type 50mm Depth**Pilot Pin 08050(A3)**

Part No.	Diameter × Depth(mm)	Part No.	Diameter × Depth(mm)	Part No.	Diameter × Depth(mm)
TK01068	18 × 50	TK00624	25 × 50	TK00627	32 × 50
TK00622	22 × 50	TK00625	26 × 50	TK00628	35 × 50
TK00623	24 × 50	TK00632	26.5 × 50		
TK00631	24.5 × 50	TK00626	28 × 50		

(6) Hi-Broach One-touch Type 25mm Depth**Pilot Pin 08025(A1)**

Part No.	Diameter × Depth(mm)	Part No.	Diameter × Depth(mm)	Part No.	Diameter × Depth(mm)
TK00336	18 × 25	TK00345	23.5 × 25	TK00354	30 × 25
TK00337	19 × 25	TK00346	24 × 25	TK00355	31 × 25
TK00338	19.5 × 25	TK00347	24.5 × 25	TK00356	32 × 25
TK00339	20 × 25	TK00348	25 × 25	TK00357	33 × 25
TK00340	21 × 25	TK00349	26 × 25	TK00358	33.5 × 25
TK00341	21.5 × 25	TK00350	26.5 × 25	TK00359	34 × 25
TK00342	22 × 25	TK00351	27 × 25	TK00360	34.5 × 25
TK00343	22.5 × 25	TK00352	28 × 25	TK00361	35 × 25
TK00344	23 × 25	TK00353	29 × 25		

(7) Hi-Broach One-touch Type 50mm Depth**Pilot Pin 08050(A3)**

Part No.	Diameter × Depth(mm)	Part No.	Diameter × Depth(mm)	Part No.	Diameter × Depth(mm)
TK00727	18 × 50	TK00733	24 × 50	TK00739	30 × 50
TK00728	19 × 50	TK00734	25 × 50	TK00740	31 × 50
TK00729	20 × 50	TK00735	26 × 50	TK00741	32 × 50
TK00730	21 × 50	TK00736	27 × 50	TK00742	33 × 50
TK00731	22 × 50	TK00737	28 × 50	TK00743	34 × 50
TK00732	23 × 50	TK00738	29 × 50	TK00744	35 × 50

11 ORDERING PARTS

When ordering parts from sales agent, please be sure to give them part number, part name and quantity.

12 ATRA ACE ARA-100A ASSEMBLY

WARNING

The illustration is for information only. Users should never disassemble parts. Contact the sales agent from whom you purchased the tool or authorized dealer should the tool need service, repair or replacement of parts.

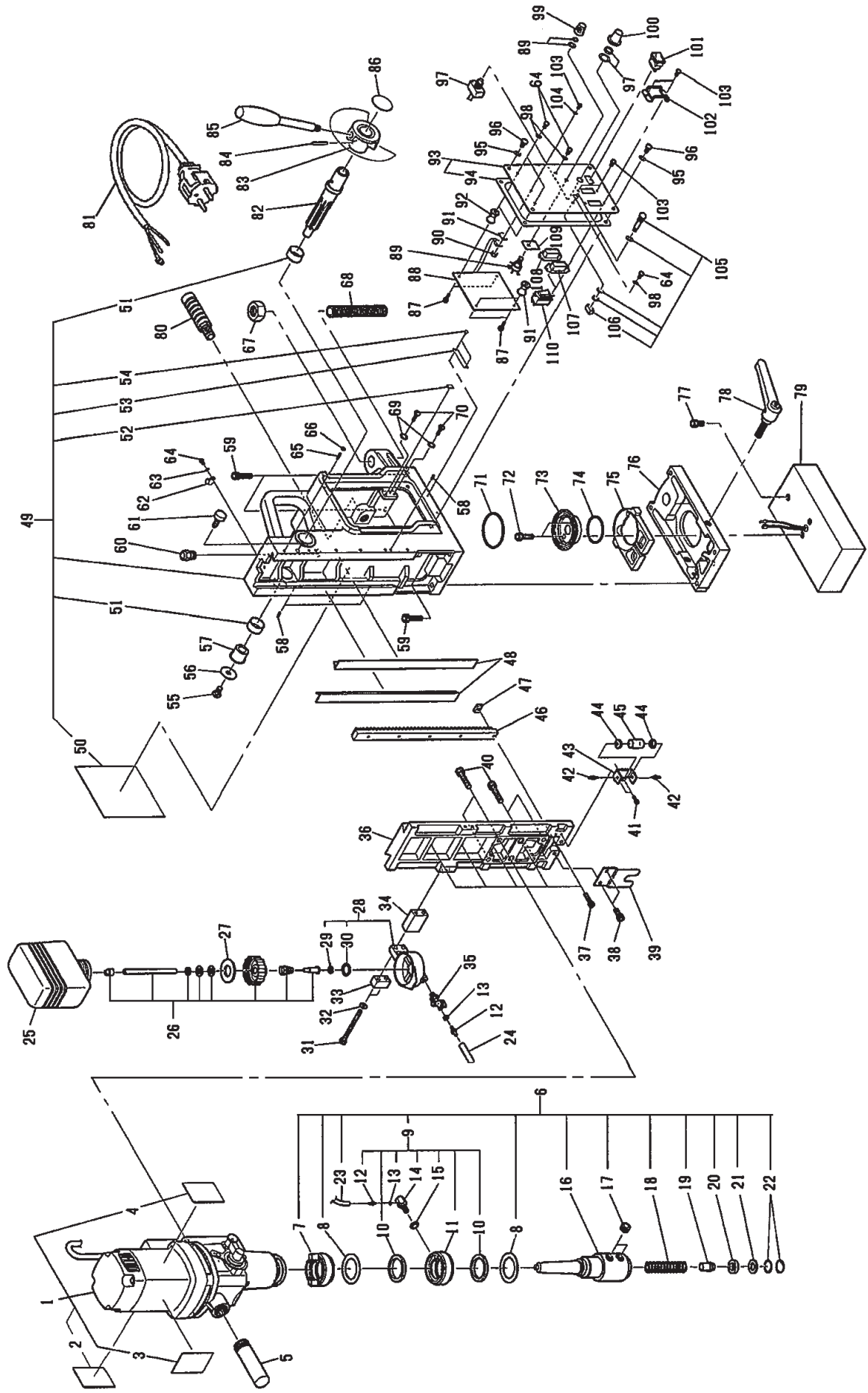

13 ATRA ACE ARA-100A PARTS LIST

The parts numbers with () are included in the Ass'y parts written above them.

No.	Part No.	Part Name	Q'ty	Price
1	TB09630	Drill Motor Ass'y (230V)	1set	
-	(TB09332)	Carbon Brush Ass'y	1set	
2	(TQ14205)	Caution Label JBO	1	
3	(TQ14442)	Caution Label Drilling	1	
4	(TQ14204)	Shift Operation Label	1	
5	TB02534	Side Handle Ass'y	1set	
6	TB09792	Holder MT03075 Side lock Ass'y	1set	
7	(TQ14338)	Key Ring	1	
8	(TP12773)	Washer 38.5x54x1	2	
9	(TB09270)	Oil Ring Ass'y	1set	
10	(TP14499)	Oil Seal GD 38x48x4	2	
11	(TQ13739)	Oil Ring	1	
12	(TP14500)	Hose Nipple	2	
13	(CP21947)	Packing S-4.7x8x0.8	2	
14	(TQ13740)	Stopper Bolt	1	
15	(TQ01050)	Hex. Nut M8	1	
16	(TQ14337)	Holder MT03075 Side lock	1	
17	(TP17597)	Hex. Socket Set Screw with Flat Point 16 x 9 special	2	
18	(TQ13735)	Spring 1.4x15x105	1	
19	(TQ13736)	Pilot Spacer s75	1	
20	(TQ13737)	Spacer 14x24.2x6	1	
21	(TQ13738)	Washer 14x23.9x3.2	1	
22	(TP10448)	Internal Retaining Ring C-14	2	
23	(TB01098)	Tube 4x7x3000 Ass'y(70mm)	1set	
24	TB01098	Tube 4x7x3000 Ass'y(450mm)	1set	
25	TQ00702	Oil Tank	1	
26	TB00516	Cap Ass'y	1set	
27	(TQ00701)	Packing Cap	1	
28	TB01380	Oil Tank Bracket Sub Ass'y	1set	
29	(TP11994)	O-ring P-4	1	
30	(CP20180)	O-ring P-18	1	
31	TP02739	Hex. Socket Head Cap Screw 6x75	2	
32	TP00092	Washer M6	2	
33	TQ13741	Guard Tank Bracket	1	
34	TQ03118	Spacer Oil Tank Bracket	1	
35	TP14495	P Valve PT1/8	1	
36	TQ13539	Slide Board	1	
37	TQ08013	Hex. Socket Head Cap Screw 5x25	5	
38	TP14178	Hex. Socket Head Cap Screw 6x10	2	
39	TQ13697	Stopper Plate	1	
40	TP02260	Hex. Socket Head Cap Screw 8x35	4	
41	TP06342	Hex. Socket Head Cap Screw 4x10	2	
42	TQ00672	Dropper Nipple	2	
43	TQ13696	Dropper Holder	1	
44	TQ00671	Dropper Packing	2	
45	TQ00670	Dropper Pipe	1	
46	TP05091	Rack	1	
47	TP02861	Stopper	1	
48	TP13832	Slide Plate	2	
49	TB09595	Body Ass'y	1set	
50	(TQ14203)	Label Explanation of function	1	
51	(TQ13694)	Bushing K5B2520	2	
52	(TQ11282)	Label Earth	1	
53	(TP04769)	Plate Serial Number	1	
54	(TP05136)	Drive Rivet No.2x4.8	2	
55	TQ13731	Hex. Socket Button Head Screw 8x12	1	
56	TQ13730	Washer 8.5x30x2	1	
57	TQ13729	Bushing	1	
58	TP04519	Hex. Socket Set Screw with Dog Point 5x18	4	
59	TP07353	Hex. Socket Head Cap Screw 8x30	4	
60	TQ07097	Cable Connector 3217	1	
61	TP02931	Set Screw	1	

No.	Part No.	Part Name	Q'ty	Price
62	TQ13733	Cable Clamp	1	
63	TP00144	Washer M4	1	
64	TP02618	Pan Head Screw 4x8	5	
65	TP02937	Hex. Socket Set Screw with Cup Point 5x20	6	
66	TP02936	Hex. Nut Type3 M5	6	
67	TP03909	Hex. Nut Type3 M20	1	
68	TQ13794	Hex. Socket Set Screw with Flat Point 20x120	1	
69	TP04464	Toothed Lock Washer BM4	2	
70	LP08489	Binding Head Screw 4x6	2	
71	CP22563	O-ring G-60		
72	TP00045	Hex. Socket Head Cap Screw 8x25	2	
73	TQ13725	Radial Shaft	1	
74	TQ13726	O-ring S-45	1	
75	TQ13544	Lock Plate	1	
76	TQ13543	Pole Plate	1	
77	TP02601	Hex. Socket Head Cap Screw 8x10	1	
78	TQ13727	Clamp Lever	1	
79	TB09605	Square Pole Ass'y	1set	
80	TQ13732	Cable Connector 3250	1	
81	TB09640	Cabtyre Cable Ass'y (A) TYPE:C-4	1set	
82	TQ13728	Pinion Shaft	1	
83	TP05042	Handle Boss	1	
84	TP09853	Spring Pin 5x34 Double	1	
85	TP00118	Rod Handle	3	
86	TP02573	NITTO Plate	1	
87	TP03193	Pan Head Screw 4x6	4	
88	TB09812	Spare Control Board Ass'y (230V)	1set	
89	TB09288	Volume Ass'y	1set	
90	TP00067	Hex. Nut Type1 M3	1	
91	TQ10553	Heat Radiation Seat CW-4	1	
92	TA91465	Rubber Support Ass'y	4set	
93	TB09608	Switch Plate Sub Ass'y	1set	
94	(TQ13755)	Packing Switch Plate	1	
95	TQ01331	Seal Washer M6	4	
96	TP02419	Pan Head Screw 6x10	4	
97	TB09289	Switch Ass'y B	1set	
98	TQ00258	Seal Washer M4	4	
99	TQ13763	Knob K-6	1	
100	TQ10085	Waterproofing Cap Black	1	
101	TB09286	Switch Ass'y A	1set	
102	TQ13764	Switch Guard	1	
103	TP03255	Pan Head Screw 3x8	5	
104	TQ01330	Seal Washer M3	1	
105	TB09330	Spare LED Lamp Ass'y	1set	
106	(LQ04533)	Housing	1	
107	TQ14209	Switch Cover (green)	1	
108	TQ14210	Switch Cover (clear)	1	
109	TQ14211	Volume Packing	1	
110	TQ13768	Switch ELE225K	2	

Accessories

	Part No.	Part Name	Q'ty	Price
	TP04305	Hex. Socket Screw Key 2.5	1	
	TP04004	Hex. Socket Screw Key 5	1	
	TP00170	Hex. Socket Screw Key 6	1	
	TP03249	Hex. Socket Screw Key 8	1	
	TP14091	Spanner 7x8	1	
	TA99027	Chain Ass'y	1set	
	TQ13795	Drill Drift No.3	1	
	TQ14213	Guard	1	
	TQ14212	Instruction Manual	1	

14 ATRA ACE ARA-100A MOTOR ASSEMBLY

The parts numbers with () are included in the Ass'y parts written above them.

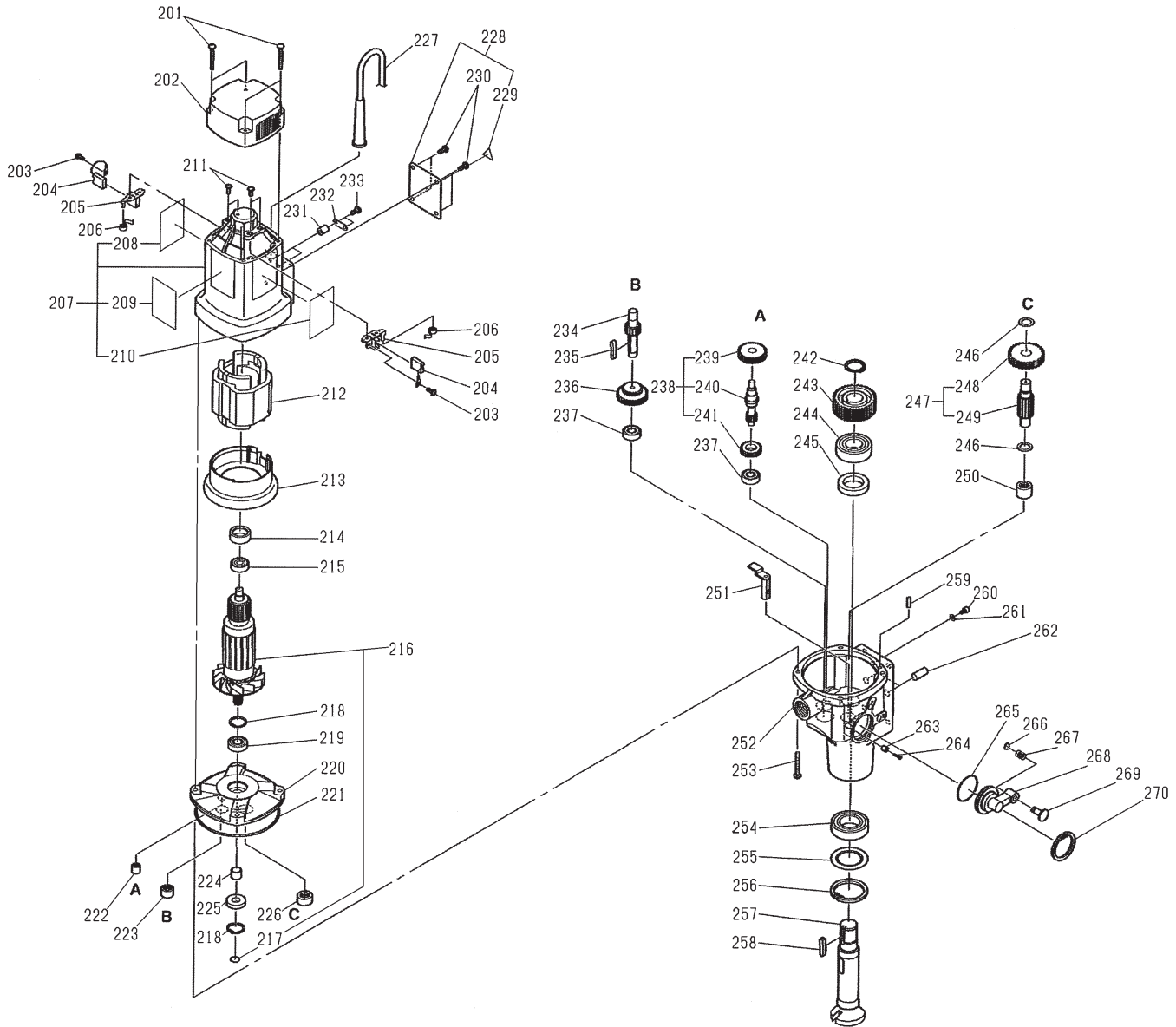

15 ATRA ACE ARA-100A MOTOR PARTS LIST

The parts numbers with () are included in the Ass'y parts written above them.

No.	Part No.	Part Name	Q'ty	Price
201	TQ13569	Pan Head Tapping Screw 4x40	4	
202	TQ13546	End Cap	1	
203	TQ13570	Pan Head Screw 4x8	2	
204	TB09332	Carbon Brush Ass'y	1set	
205	TB09184	Brush Holder Ass'y	2set	
206	TQ13553	Spiral Spring	2	
207	TB09600	Motor Case Sub Ass'y	1set	
208	(TQ14205)	Caution Label JBO	1	
209	(TQ14442)	Caution Label Drilling	1	
210	(TQ14204)	Label Change Operation	1	
211	LP30898	Pan Head Screw 4x12	4	
212	TB09631	Stator Ass'y (230V)	1set	
213	TQ13547	Shroud	1	
214	TQ13564	Rubber Cap	1	
215	TP01913	Ball Bearing 6000ZZ	1	
216	TB09632	Rotor Ass'y (230V)	1set	
217	(TQ14599)	Stop Ring O-10.2x1	1	
218	TP01036	Internal Retaining Ring C-28	2	
219	TP00498	Ball Bearing 6001ZZ	1	
220	TQ13541	Motor Flange	1	
221	LP11804	O-ring S-110	1	
222	TQ04099	Needle Bearing HK0810	1	
223	TP15751	Needle Bearing HK1212	1	
224	TQ13563	Collar 12x15x12	1	
225	TQ13558	Teflon Lip Seal	1	
226	TQ13812	Needle Bearing RNA4900R	1	
227	TB09192	Motor Cabtyre Cord Ass'y	1set	
228	TB09809	Motor Case Cover Ass'y	1set	
229	(TQ14461)	Electric Shock Label	1	
230	LP13008	Pan Head Tapping Screw 5x12	4	
231	TQ00741	Spacer 4EP-4	2	
232	TP14459	Cord Stopper	1	
233	TP14488	Pan Head Tapping Screw 4x20	2	
234	TQ13710	Slide Gear Shaft 1.5x12	1	
235	TQ13712	Parallel Key Both Ends Round 5x5x30	1	

No.	Part No.	Part Name	Q'ty	Price
236	TQ13711	Spur Gear 1x43-1x27	1	
237	TQ13920	Ball Bearing 6000	2	
238	TB09260	Gear Shaft A Ass'y	1set	
239	(TQ13708)	Helical Gear 1.25x29	1	
240	(TQ13707)	Gear Shaft 1x13	1	
241	(TQ13709)	Spur Gear 1x28	1	
242	TQ05256	External Retaining Ring C-24	1	
243	TQ13705	Spur Gear 1.5x39	1	
244	TQ13873	Ball Bearing 6205	1	
245	TQ13702	Oil Seal AE1679AO	1	
246	TQ13719	Washer 14.3x21.7x1	2	
247	TB09262	Gear Shaft C Ass'y	1set	
248	(TQ13714)	Spur Gear 1.5x31	1	
249	(TQ13713)	Gear Shaft 1.5x12	1	
250	TQ13699	Needle Bearing HK14/16R	1	
251	TB09263	Shift Bar Ass'y	1set	
252	TQ13540	Gear Box	1	
253	TQ13800	Pan Head Tapping Screw 5x40	4	
254	TQ13701	Ball Bearing 6006LLU	1	
255	TQ13703	Bearing Cover	1	
256	CP01109	Internal Retaining Ring C-55	1	
257	TQ14336	Spindle MT3	1	
258	TQ13706	Parallel Key 6x6x22	1	
259	TQ12425	Knock-pin MS5-15	1	
260	TP16405	Hex. Socket Head Cap Screw 4x5	1	
261	TQ00258	Seal Washer M4	1	
262	TQ13782	Knock-pin MSTP10-25	2	
263	TQ13720	Collar 4x7x7	1	
264	TQ13721	Hex. Socket Low Head Cap Screw 4x12	1	
265	CQ09185	O-ring S-39	1	
266	TV00091	External Retaining Ring ISTW-8	1	
267	TQ13718	Spring 0.5x9x12	1	
268	TQ13542	Shift Lever	1	
269	TQ13717	Plunger Pin	1	
270	TQ13722	Internal Retaining Ring IRTW-42	1	

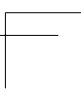
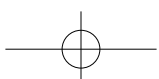
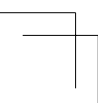
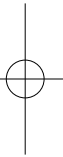
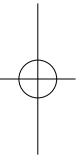
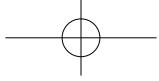
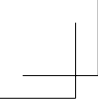



■ Overseas Affiliates / Offices

NITTO KOHKI U.S.A., INC.

46 CHANCELLOR DRIVE, ROSELLE,
IL 60172 U.S.A.

TEL:+1-630-924-9393 FAX:+1-630-924-0303

NITTO KOHKI EUROPE CO., LTD.

UNIT A5, LANGHAM PARK INDUSTRIAL ESTATE,
MAPLE ROAD, CASTLE DONINGTON,
DERBYSHIRE DE74 2UT, U.K.

TEL:+44-1332-653800 FAX:+44-1332-987273

NITTO KOHKI DEUTSCHLAND GMBH

LERCHENSTR.47 D-71144 STEINENBRONN,
GERMANY

TEL:+49-7-157-22436 FAX:+49-7-157-22437

NITTO KOHKI CO., LTD., SINGAPORE BRANCH

10 UBI CRESCENT #01-62,
UBI TECHPARK LOBBY D, SINGAPORE 408564,

TEL:+65-6227-5360 FAX:+65-6227-0192

NITTO KOHKI AUSTRALIA PTY. LTD.

77 BRANDL ST., BRISBANE TECHNOLOGY PARK,
EIGHT MILE PLAINS QLD 4113 AUSTRALIA

TEL:+61-7-3340-4600 FAX:+61-7-3340-4640

NITTO KOHKI CO., LTD.,

BANGKOK REPRESENTATIVE OFFICE

M&A BUSINESS CENTER 38Q. HOUSE CONVENT BLDG.,
7TH FLOOR, UNIT 7A, CONVENT RD., SILOM, BANGRAK,
BANGKOK 10500 THAILAND

TEL:+66-2-632-0307 FAX:+66-2-632-0308

NITTO KOHKI (SHANGHAI) CO., LTD.

ROOM1506, SUITE C, ORIENT INTERNATIONAL PLAZA,
NO85 LOUSHANGUAN ROAD, SHANGHAI, 200336, CHINA

TEL: +86-21-6415-3935 FAX:+86-21-6472-6957

NITTO KOHKI CO., LTD.,

SHENZHEN REPRESENTATIVE OFFICE

2005C SHENZHEN ICC TOWER, FUHUASANLU 168,
FUTIAN DISTRICT, SHENZHEN, GUANGDONG, 518048 CHINA

TEL: +86-755-8375-2185 FAX:+86-755-8375-2187

EC DECLARATION OF CONFORMITY

We hereby declare that the following our product conforms with the essential health and safety requirements of EU Directives.

Brand Name: NITTO KOHKI
Product: PORTABLE MAGNETIC DRILLING MACHINE
Model: ARA-100A
Serial No: In the case of 6 digits serial number.

X X X X X X

→ Consecutive numbers (00001~99999)

→ Last digit (0-9) of year (A.D.)

In the case of 7 digits serial number.

X X X X X X X

→ Consecutive numbers (00001~99999)

→ Last two digits (00-99) of year (A.D.)

Manufacturer: NITTO KOHKI Co., Ltd.
9-4, NAKAIKEGAMI 2-CHOME, OHTA-KU, TOKYO, 146-8555, JAPAN
Tel:+81-3-3755-1111 Fax:+81-3-3753-8791

Authorised person to prepare the technical construction file(TCF) in the community:

Masatoshi Ogue

President

NITTO KOHKI EUROPE Co., Ltd.
UNIT A5, LANGHAM PARK INDUSTRIAL ESTATE, MAPLE ROAD,
CASTLE DONINGTON, DERBYSHIRE DE74 2UT, U.K.
Tel:+44-1332-653800 Fax:+44-1332-987273

Directive: Machinery Directive 2006/42/EC
EMC Directive 2014/30/EU
RoHS Directive 2011/65/EU

The above product has been evaluated for conformity with above directives using the following European standards. The technical construction file (TCF) for this product is retained at the above manufacturer's location.

Machinery Directive: EN ISO12100:2010, EN60204-1:2006

EMC Directive: EN55014-1:2006+A1:2009+A2:2011, EN55014-2:1997+A1:2001+A2:2008
EN61000-3-2:2014, EN61000-3-3:2013

RoHS Directive: EN50581:2012