

INSTRUCTION MANUAL

PNEUMATIC CHAMFERING TOOL

Please read this manual carefully before you attempt to use your tool so that you may use it properly and safely.

CIRCUIT BEVELER Model CBR-03 PROFESSIONAL TOOL

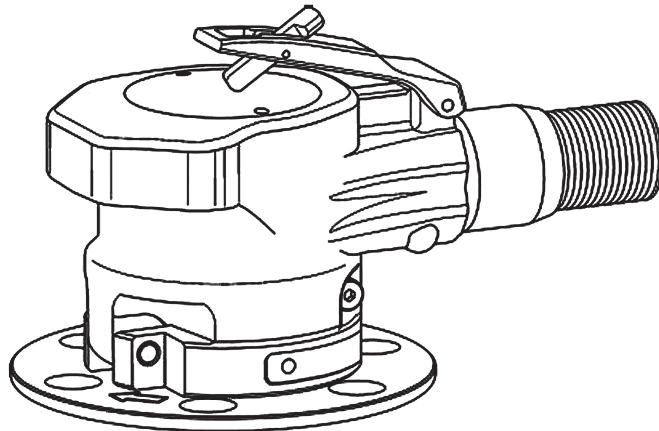

Specifications

Model		CBR-03
Maximum Operating Pressure		0.6 MPa
Air Consumption (No Load)		0.65 m ³ /min
Rated Speed (No Load)		12,000 min ⁻¹
Chamfering Capacity		R3 (Mild Steel)
Minimum workpiece thickness		6 mm
Mass (Weight)	without handle	2.2 kg
	with handle	2.3 kg
Sound Pressure Level		81 dB(A)
Sound Power Level		92 dB(A)
Vibration Level [Uncertainty K] (according to ISO20643)	Main body	2.50 m/s ² [0.89 m/s ²]
	handle	3.40 m/s ² [0.64 m/s ²]

Two indexable inserts for mildsteel come with the product.

Due to continuous product development/improvement the specifications and configurations in this document are subject to change without prior notice.



Manufactured by :
NITTO KOHKI Co., Ltd.
2-9-4, Nakaikegami, Ohta-ku,
Tokyo, 146-8555, Japan
TEL : (81)-3-3755-1111
FAX : (81)-3-3753-8791
E-mail : overseas@nitto-kohki.co.jp
URL : www.nitto-kohki.co.jp

Keep the manual handy – so you can use it whenever necessary.

Original Instructions

Thank you very much for your purchase of this **Nitto Kohki products.**







Before using your tool, please read this manual carefully so that you may use it properly to get the most out of it.

Please keep the manual handy - so you can use it whenever necessary.



- **English** : Please ask your dealer or distributor for instruction manual in local language(s).
- **German** : Bitte fragen Sie Ihren Händler nach eine Betriebsanleitung in Landessprache.
- **French** : S'il vous plait, veuillez demandez á votre fournisseur de manuel instruction en langue locale.
- **Spanish** : Por favor, contacte con su distribuidor para el manual de instrucciones en español.
- **Portuguese** : Por favor pessa ao seo agente ou distribuidor o manual de instrucces ih linguagen local.
- **Italian** : Per Manuale Istruzioni in lingua locale Vi preghiamo di rivolgervi al rivenditore o distributore.
- **Dutch** : Vraag uw handelaar om een nederladstalige gebruiksaanwijzing.
- **Swedish** : Be er lokala Åtreförsäljare eller distributör om manualer på svenska.
- **Danish** : Venligst henvend Dem til den danske distributør for instructions manualer.
- **Polish** : Proszę pytać swojego dealera lub dystrybutora o instrukcje obsługi w języku localnym.
- **中文** : 請向當地供應商或經銷商詢問中文使用說明書

CONTENTS	page
IMPORTANT SAFETY INSTRUCTIONS	2
GENERAL: TOOLS	2
GENERAL: PNEUMATIC TOOLS	3
INSTRUCTIONS FOR THIS TOOL	4
1. USAGE	4
2. CHECK THE CONTENTS OF THE PACKAGE	4
3. NAME OF PARTS	4
4. AIR SUPPLY	5
5. PREPARATION	5
6. HOW TO OPERATE THE TOOL	5
7. STORAGE.....	7
8. ORDERING SERVICE PARTS	7
9. OPTIONAL PARTS	7
10. EXPLODED DIAGRAM : CB-02	8

PICTOGRAM

-  Warning: It might be dangerous to operate the tool if the instructions supplied are not followed.
-  Using this tool improperly could result in serious injury. Read the instruction manual before using.
-  Always wear suitable eye protection.
-  Always wear suitable hearing protection.
-  Always wear respiratory protective equipment (PPE).
-  Always wear protective gloves for protection of hands from Vibration, Shock and Burns.

The following Safety notations are used throughout the manual to highlight safety precautions for the user and for the tool.

	WARNING:	Indicates a potentially hazardous situation which, if not avoided by following the instructions given, could result in death or serious injury.
	CAUTION:	Indicates a potentially hazardous situation which, if not avoided by following the instructions given, could result in injury or material damage.

Please note, however, that failure to observe safety precautions under the “ **Caution**” category could result in a serious occurrence depending on the situation: please observe all safety precautions in the manual.

Caution: Important precautions for tool setup, operation and maintenance.

IMPORTANT SAFETY INSTRUCTIONS

When using the tool, please observe the safety precautions below to prevent possible accident or injury.

GENERAL: TOOLS

WARNING

TO OPERATORS

- **Wear proper clothing for the type of work being done.**
Take care so that clothing, ties, hair, etc. will not become entangled with the moving parts. If items become entangled it will cause the operator to be pulled towards the tool and lead to possible cause of accident or injury.
- **Always wear suitable eye protection.**
Vision correction glasses are not safety glasses. Always wear appropriate safety glasses when doing your job.
- **Always wear suitable hearing protection.**
- **Wear respiratory protective equipment (PPE).**
Wear respiratory protective equipment (PPE) when working in an environment where dust particles are generated in operation.
- **Avoid working posture that is too stressful.**
Always ensure a firm footing and well balanced posture.
- **Do not operate the tool if you are too tired.**
- **Never touch any moving parts of the tool when running.**

ABOUT WORK AREA

- **Keep the work area clean.**
Cluttered work areas (e.g. workbench) invite accidents.
- **Carefully select the work area.**
Do not expose tool to rain.
Do not use tool in a wet or soaked area.
See that the work area is adequately illuminated.
- **Never work near inflammable liquid or in a potentially explosive atmosphere.**
- **Keep children away from the work area.**
Keep children and unauthorized people away from the work area to avoid accident or injury.
- **Some tools generate high noise levels.**
Check to be sure that the use of this tool conforms to all local noise regulations.

BEFORE OPERATION

- **Inspect tool before use.**
Before using, check that screws are securely tightened, that any protective cover or guard is securely in place, other parts are free from damage and that the tool runs as it should.
Check that moving parts are properly adjusted for positioning and tightened, that parts are free from damage and properly mounted, and that all other parts are in good condition for normal operation.
Should you find any damage to the protective cover or other part, replace it in accordance with the Operation Manual. If there are no instructions in the Manual, please contact the sales agent through which you have purchased your tool or an authorized dealer near you for repair.
Likewise, if a switch failure occurs, contact sales agent through which you have purchased your tool or an authorized dealer near you for repair. .
Do not use the tool if it does not start or stop with the start/stop switch.
- **Securely mount cutter**
An improperly mounted cutter may fly out, causing possible damage to the tool or injury to the operator.
- **Always remove spanner, wrench, etc., once adjustment has been made with them.**
- **Use a tool appropriate for the application.**
Avoid heavy-duty application that is beyond the capacity of tool.
- **Do not use the tool for purposes other than what it is designed for.**
- **Do not abuse tool.**
Use tool in accordance with the specifications: you'll get the most out of it while ensuring safety.
- **Securely fasten workpiece in place.**
Use a vice or clamp to securely fasten the workpiece in place. It is much safer this way than holding it in your hand, allowing you to operate the tool with both hands.

ABOUT HANDLING

- **How to store tool.**
When the tool is not used, store it in a dry area and out of reach of children.
- **How to carry tool.**
Do not touch the start switch while the tool is being carried.
- **Do not leave the tool unattended while it is running.**
Turn off the start switch and disconnect the tool from

power source. Do not leave the work area until the tool comes to a complete stop.

MAINTENANCE/SERVICE

- **Do not take apart or modify tool.**
Disassembly or modification carried out without the supervision of a qualified or authorized service engineer could result in an accident or injury.
- **Inspect cutting tool and accessories, etc.**
Always check to see that cutting tool and accessories, etc. are in good operating condition without damage or deterioration before you mount them on the tool. Should you find any damage to an accessory or part, please contact sales agent through which you have purchased your tool or an authorized dealer near you for repair.
- **Check parts for damage.**
When you have found damage to accessory or other part, carefully check the damaged part to determine the extent of influence it has upon the functions of the tool – that is, determine whether it can still perform its normal functions.
Check to see that the linkage of the moving parts is OK, that all parts are OK without damage, that they are properly mounted, and that the tool functions normally. Should you find any damage to an accessory or part that may hamper proper functioning of the tool, please contact sales agent through which you have purchased your tool or an authorized dealer near you for repair.
- **Have your tool repaired at an authorized Nitto Service Center.**
For repair or parts replacement, please contact the sales agent through which you have purchased your tool or an authorized dealer near you.
- **Use only Nitto genuine parts.**
Use of improper parts may result in serious occurrence.
To obtain a Nitto genuine part, consult this Manual or contact the sales agent from which you have purchased your tool directly.
- **Do not detach label or nameplate from tool.**
When a label/nameplate gets damaged, worn or becomes missing, contact the sales agent through which you have purchased your tool or Nitto Kohki Co. Ltd, directly for a replacement.

DISPOSAL

- When a tool is taken permanently out of service, it is advised that the tool is disassembled, degreased and parts separated by material and recycled locally in the appropriate manner.

GENERAL: PNEUMATIC TOOLS

WARNING

- **Use appropriate air pressure.**
Excessively high air pressure will increase the number of revolutions or strokes causing not only potential premature failure/breakage but could also lead to an unexpected accident or injury.
- **Connect tool to air supply line.**
There are various types of pipes running in a factory in addition to the pneumatic line (such as oxygen, nitrogen, gas and water). For this reason, always ensure that you are connecting to the pneumatic line.
- **Start tool properly.**
Turn the start switch OFF before connecting to the air supply line.
- **Always disconnect the tool from the air supply line before putting on/taking off any accessory and prior to carrying out any maintenance work.**
- **Avoid exposure to exhaust air.**
Pneumatic tool exhaust air contains oil and contaminated moisture. Make sure the exhaust air is not directed towards your face or anyone else within the work area.
- **Keep tool off electricity.**
This pneumatic tool is not electrically insulated. To avoid a potential electric shock do not use where there is a possibility of coming into contact with live electricity.

CAUTION

- **Handle tool carefully.**
Abusive use of tool could invite failure or accident.
Do not throw, drop or shock the tool.
- **Handle connecting hose carefully.**
Do not carry the tool by the air hose.
Do not pull the air hose to disconnect.

INSTRUCTIONS FOR THIS TOOL

About Your Tool

WARNING

- **Protect your body from the chips/filings.**
Hot chips/filings may fly out from the work piece. Always wear safety glasses, dust mask, earplugs, gloves (except knitted gloves) and long-sleeved garment. Keep your face well away from the work piece.
- **Use our original Indexable Inserts.**
- **Do not use worn or damaged Indexable Inserts.**

1. USAGE

This tool is a pneumatic hand tool designed for radius chamfering of mild steel workpieces with Indexable Inserts.

2. CHECK THE CONTENTS OF THE PACKAGE

Check the contents and make sure that the tool does not have any damage which may have occurred during transportation. The contents should correspond to the list as follows. In case of damage/missing parts, please contact the sales agent from whom you purchased the tool.

Package Contents	Qty	Check
CIRCUIT BEVELER CBR-03	1set	
SPANNER T-15D	1	
HANDLE Ass'y	1	
INDEXABLE INSERT	2	
INDEXABLE INSERT SET SCREW	3	
INSTRUCTION MANUAL	1	
DECLARATION OF CONFORMITY	1	
CAUTION FOR USE	1	

3. NAME OF PARTS

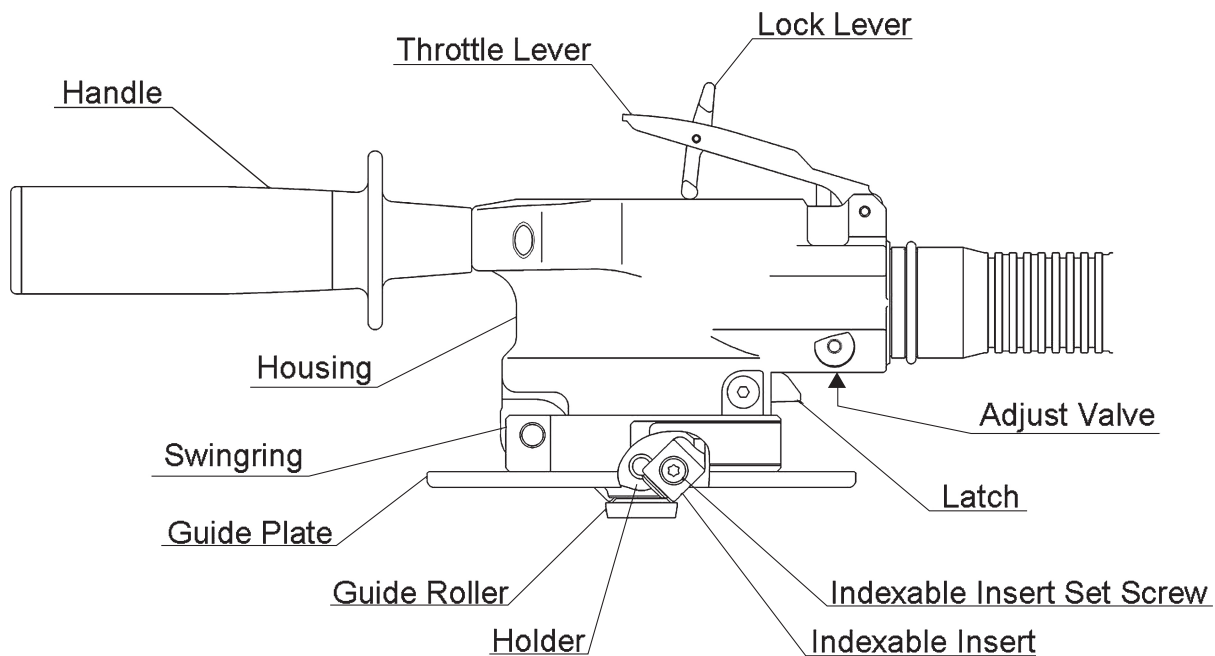

Fig.1

4. AIR SUPPLY

⚠ CAUTION

- Draw off drainage before starting operation. If the drainage enters into the tool, it can freeze around the exhaust port of the tool and result in output power reduction.

4-1. Air Pressure

Adjust air pressure to 0.6MPa (or 6 kgf/cm²) with the air regulator. Lower pressure may result in insufficient performance. Higher pressure may result in premature wornout of parts. It is important to maintain the proper pressure with pressure regulator on air line.

4-2. Air Line (Fig.2)

Use a 9.5 mm (3/8") I.D. air hose between the compressor and the tool. Compressed air comes to be cooled down and its drain be separated, as soon as the air leaves the compressor. The drain, however, is condensed in the piping, and can enter into the tool mechanism, and may cause malfunction. So, install an air filter and an oiler between the compressor and the tool.

4-3. oiler

Install an oiler between the compressor and the tool. Use machine oil ISO VG-10 for lubrication and rust prevention. Negligence of the oil supply may cause damages on the tool. Lubricating the tool with high viscosity oil reduces the tool performance.

4-4. Lubrication (Fig.2)

Before starting the tool, disconnect air hose from the tool and supply a few drops of machine oil ISO VG-10 to the air inlet port of the tool. Then reconnect and make idle running for a few seconds so that the oil should reach every part in the tool.

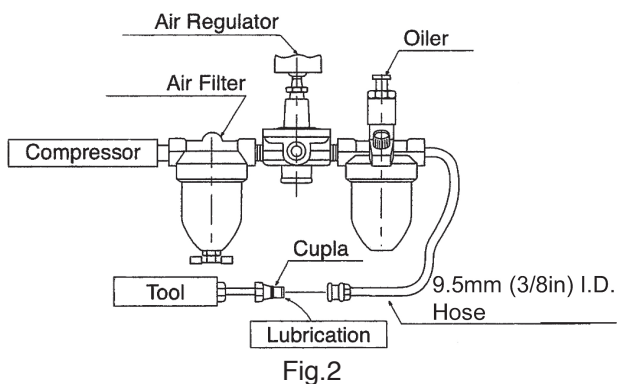

5. PREPARATION

⚠ WARNING

- Always disconnect the air supply hose from the tool before preparation.

5-1. How to fix the Handle Ass'y

⚠ CAUTION

- Remove any foreign matter around the screw hole before fixing the Handle Ass'y. Otherwise the screw thread will be damaged.

Screw the Handle Ass'y to the desired position for your convenience.(Fig.3)

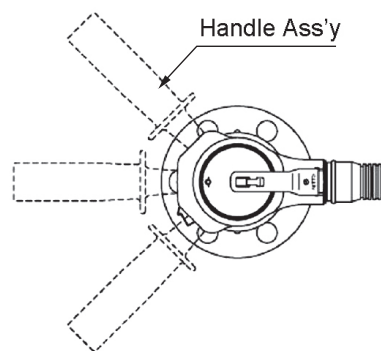

6. HOW TO OPERATE THE TOOL

⚠ WARNING

- Always wear safety glasses during operating the tool. Wear respiratory protection when working in an environment where dust particles are generated during operation.
- Make sure the Throttle Lever is in the OFF position before connecting the air supply hose to the tool.
- Always disconnect the air supply hose from the tool before putting on/taking off indexable inserts or replacing parts.
- Never touch any moving parts of the tool when running.

6-1 Dimensions of material to be chamfered

Minimum chamfering dimensions are hole diameter 22mm, radius 11mm, and plate thickness 6mm. Also chamfering of groove, minimum depth required is 9mm. (Fig.4)

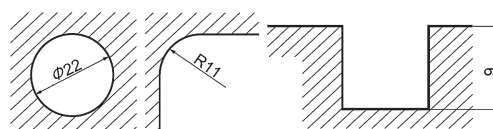

6-2. Start and Stop (Fig.5)

- (1) Check that a Throttle Lever is turned off and connecting the tool to the hose leading to air supply line.
- (2) Hold the tool, release the Lock Lever, and grasp the Throttle Lever to start.
- (3) When the Throttle Lever is released, it will automatically turn off.

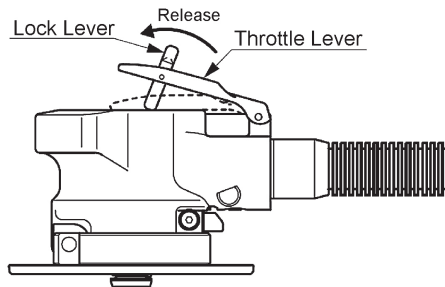

Fig.5

6-3. How To Replace the Indexable Inserts

WARNING

- Always disconnect the air supply hose from the tool before replacing indexable inserts.
- Allow the indexable insert adequate time to cool off after use as indexable inserts can reach extreme temperatures.
- Be careful not to get fingers caught between the Swinging and Housing when opening or closing the Swinging.

CAUTION

- Replace two Indexable Inserts at the same time. When only one Indexable Insert is replaced, smooth chamfering surface cannot be obtained and the life of the Indexable Insert can become shorter.
- Remove the swarf on the surface of indexable insert spindle before installing a new indexable insert.

- (1) Timing of replacement. (Four sides of each tip can be used.)

A dull Indexable Insert may be dangerous as it may chip off or damage the tool mechanism by vibration. Therefore, it must be replaced with a new genuine Indexable Insert, when the following cases happen.

- a. Indexable Insert damaged.
- b. Sparks when chamfering.
- c. Chamfering surface become rough.
- d. Cutting ability worsened.

(2) How to replace the Indexable Inserts

- a. Pressing the Latch unlocks the Swinging and the Swinging opens in the direction of the arrow. (Fig.6)
- b. Loosen the Indexable Insert Set Screw with the accessory Spanner T-15D and remove the Indexable Insert. (Fig.7)
- c. Install the new Indexable Insert (or the Indexable Insert rotated to a fresh edge), making sure it is in the correct direction, and fasten it with the Indexable Insert Set Screw.
- d. Also replace the other Indexable Insert in order of the above b. and c.
- e. Put the Swinging back into its place. The Latch automatically locks the Swinging.
- f. Ensure that the Swinging is securely fixed.

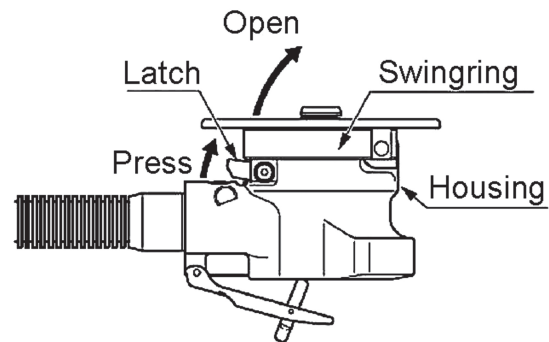

Fig.6

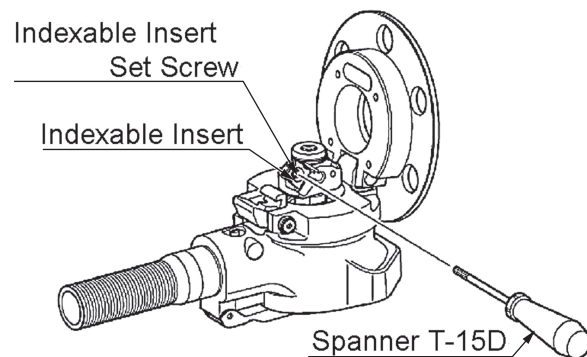

Fig.7

6-4. Adjusting the Rotation Speed

WARNING

- Never touch any moving parts of the tool when running.

Turning the Adjust Valve with a flat-blade screwdriver changes the amount of airflow to adjust the rotation speed.

When the slot of the Adjust Valve is positioned horizontally against the Housing axis line, the tool reaches its maximum rotation speed.

Adjust the rotation speed according to the chamfering work. (Fig.8)

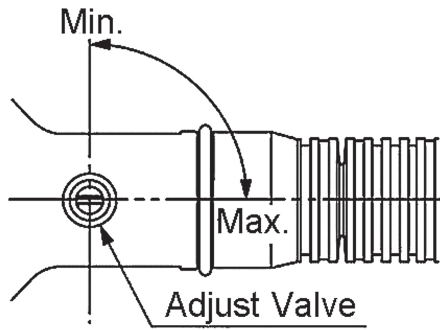

Fig.8

6-5. How to use

! CAUTION

- Always start the tool prior to contacting the work piece then slowly engage the material. Never start the motor with pressing the tool against the work piece, nor introduce the indexable inserts to the work piece as abrupt or sharp actions. This can cause damage to the indexable insert or tool.
 - If the initial cut is such an edge as in Fig. 9, before chamfering, grind the edge off. Initially cutting an edge will give a heavy shock to the Indexable Inserts. This can cause damage to the Indexable Inserts, malfunction of the tool, or injury to the operator.
 - When chamfering, fix the work piece firmly. Especially, small parts must be held securely with a device such as a vice.
- (1) Firmly hold the tool, release the lock lever, and depress the throttle lever to start the tool.
 - (2) Place the Guide Plate on the workpiece, hold the Guide Roller against the workpiece, and slowly pull the tool towards you or push it forward to introduce the indexable inserts to the material. (Fig.10)

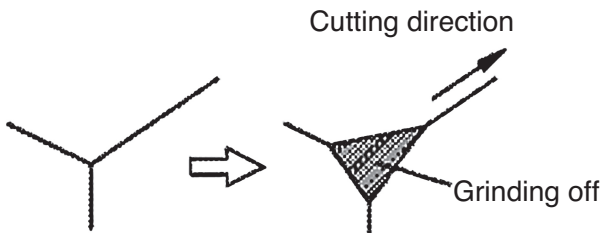

Fig.9

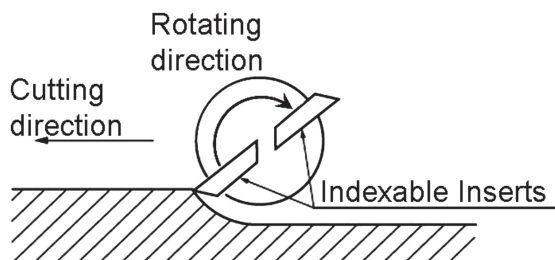

Fig.10

7. STORAGE AND MAINTENANCE

7-1. Storage

! CAUTION

- When tool is not used, store it out of reach of children.

Avoid storing the tool in a location subject to high humidity. If the tool is left as it is used, residual moisture on the inside can cause rusting. Before storing, and after operation, oil the tool at the air inlet with machine oil ISO VG-10 and run it for a short time.

7-2. Maintenance

With prolonged use, the Indexable Insert supporting section of the Holder will sag. The sag will cause damage to the Indexable Insert. Therefore, the suggested Holder should be replaced. (Fig.11).

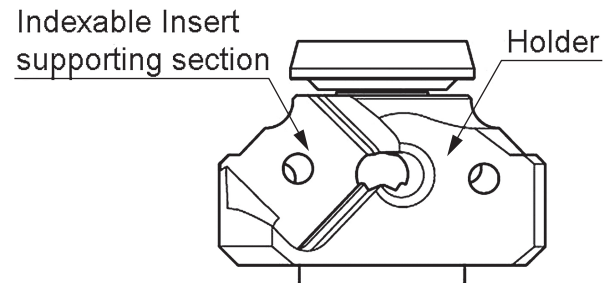

Fig.11

8. ORDERING SERVICE PARTS

- For further operational and handling information or for replacement of parts and components, contact the company from whom you purchased the tool or an authorized dealer.
- In ordering parts and components give each part number, part name and quantity required.
- Use only NITTO genuine parts.

9. OPTIONAL PARTS

Part No.	Description	Qty
TB09042	150mmOD Guide Plate Ass'y (· 150mmOD Guide Plate : 1 · Label Rotation Direction : 1 · Hexalobular Internal Socket Countersunk Head Screw 4x10 : 4 · Leaflet How to change Guide Plate : 1)	1set

10 EXPLODED DIAGRAM : CBR-03

⚠ WARNING

This diagram is for your reference only. Do not attempt to service or repair the Tool. Do not take the Tool apart. Contact an authorized Nitto dealer for all service and repair of the Tool. Improper service and repair can cause accidents and service injuries. Never attempt to modify the Tool. Never attempt service or repair the Tool yourself.

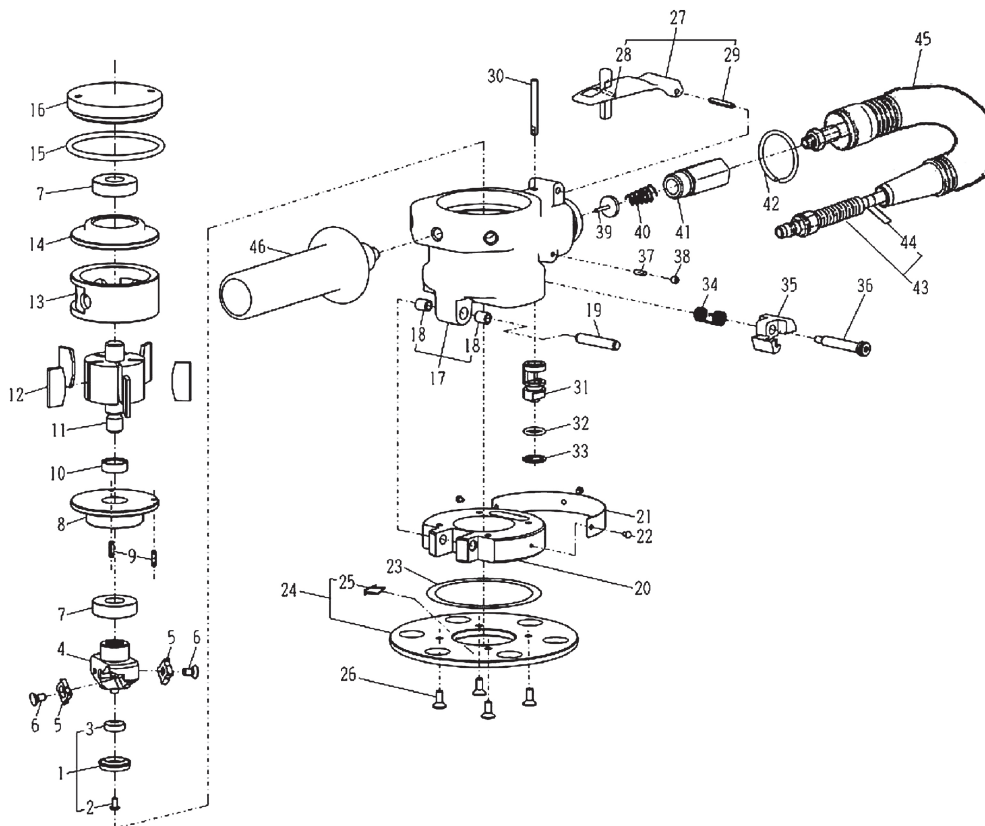

The part numbers with () are included in the Ass'y parts written above them.

No.	Part No.	Description	Qty
1	TB08982	Guide Roller	1set
2	(TQ13509)	Slotted Flat-head Screw 3x6	1
3	(TQ07225)	Ball Bearing 695ZZ	1
4	TQ13138	Holder	1
5	TB09018	Indexable Insert	1set
6	TQ01629	Indexable Insert Set Screw	2
7	TP00498	Ball Bearing 6001ZZ	2
8	TQ13137	Lower Bearing Case	1
9	TP12435	Spring Pin 2.5x10	2
10	TP04036	Distance Collar	1
11	TQ13135	Rotor	1
12	TB08974	Blade Ass'y (5pcs)	1set
13	TQ13134	Cylinder	1
14	TP04035	Upper Bearing Case	1
15	TQ13150	O-ring JASO-F404	1
16	TQ13149	Cap	1
17	TB08971	Housing Ass'y	1set
18	(TQ13452)	Bushing 6x8x8	2
19	TQ13294	Parallel Pin B 6x32	1
20	TQ13295	Swingring	1set
21	TQ13142	Model Number Plate	1
22	TP17131	Drive Rivet No.3.2	3
23	TQ13143	Shim t0.05	※ 1
	TQ13144	Shim t0.1	
	TQ13145	Shim t0.2	
24	TB08972	120mmOD Guide Plate Ass'y	1set
25	(TP12437)	Label Rotation Direction	1
26	TQ13159	Hexalobular Internal Socket Countersunk Head Screw 4x10	4

No.	Part No.	Description	Qty
27	TB01152	Lever Ass'y	1set
28	(TP05498)	SpringPin 2x16	1
29	(TQ00460)	SpringPin 3x22	1
30	TQ13213	Spool	1
31	TQ13148	Adjust Valve	1
32	TP11992	O-ring KS-9	1
33	TQ00786	Internal Retaining Ring IRTW-14	1
34	TQ13152	Double Torsion Spring	1
35	TQ13151	Latch	1
36	TQ13153	Shoulder Screw 6x30	1
37	TQ12230	Parallel Pin A 3x8	1
38	CP05247	Hex. Socket Set Screw with Flat Point 4x5	1
39	TB08978	Valve Ass'y	1set
40	CP00876	Valve Spring	1
41	TQ13425	Bushing M16xRc1/4x48	1
42	TP09153	Stop Ring O-28.5x2	1
43	TB09060	Air Hose M Ass'y	1set
44	(TQ11519)	Label Lubrication	1
45	TQ01664	Exhaust Hose	1

※ 1 Qty. vary per product.

Accessories

No.	Part No.	Description	Qty
46	TB08265	Handle Ass'y	1set
	TQ01683	SPANNER T-15D	1
	TQ01629	Indexable Insert Set Screw	1
	TQ13155	Instruction Manual	1



■ Overseas Affiliates / Offices

NITTO KOHKI U.S.A., INC.

46 Chancellor Drive, Roselle, IL 60172 U.S.A.

Tel:(1)-630-924-9393 Fax:(1)-630-924-0303

NITTO KOHKI EUROPE CO., LTD.

Unit 21, The Empire Centre Imperial Way,
Watford Herts, WD24 4TS, U.K.

Tel:(44)-1-923-239668 Fax:(44)-1-923-248815

NITTO KOHKI DEUTSCHLAND GMBH

Lerchenstr.47 D-71144 Steinenbronn, Germany

Tel:(49)-7-157-22436 Fax:(49)-7-157-22437

NITTO KOHKI CO., LTD., SINGAPORE BRANCH

10 UBI CRESCENT #01-62,
UBI TECHPARK LOBBY D, SINGAPORE 408564,

Tel:(65)-6227-5360 Fax:(65)-6227-0192

NITTO KOHKI AUSTRALIA PTY. LTD.

77 Brandl St., Brisbane Technology Park,
Eight Mile Plains QLD 4113 Australia

Tel:(61)-7-3340-4600 Fax:(61)-7-3340-4640

NITTO KOHKI CO., LTD.,

BANGKOK REPRESENTATIVE OFFICE

M&A Business Center 38Q. House Convent Bldg.,
7th Floor, Unit 7A, Convent Rd., Silom, Bangrak,
Bangkok 10500 Thailand

Tel:(66)-2-632-0307 Fax:(66)-2-632-0308

NITTO KOHKI (SHANGHAI) CO., LTD.

Room1506, suite C, Orient International Plaza,
NO85 LouShanGuan Road,Shanghai, 200336, CHINA

Tel: (86)-21-6415-3935 Fax:(86)-21-6472-6957

NITTO KOHKI CO., LTD.,

SHENZHEN REPRESENTATIVE OFFICE

2005C Shenzhen ICC Tower, Fuhuasanlu 168, Futian District,
Shenzhen, Guangdong, 518048 China

Tel: (86)-755-8375-2185 Fax:(86)-755-8375-2187

EC DECLARATION OF CONFORMITY

We hereby declare that the following our product conforms with the essential health and safety requirements of EU Directives.

Product: PNEUMATIC CHAMFERING TOOL
 Model: CIRCUIT BEVELER : CBR-03
 Serial No: In the case of 6 digits serial number.
 X X X X X X
 ↳ Consecutive numbers (00001~99999)
 ↳ Last digit (0-9) of year (A.D.)
 In the case of 7 digits serial number.
 X X X X X X X
 ↳ Consecutive numbers (00001~99999)
 ↳ Last two digits (00-99) of year (A.D.)

Manufacturer: NITTO KOHKI Co., Ltd.
2-9-4, Nakaikegami, Ohta-ku, Tokyo, 146-8555, Japan

Authorised person to prepare the technical construction file(TCF) in the community:

Masatoshi Ogue
President

NITTO KOHKI EUROPE Co., Ltd.
Unit21, Empire Centre, Imperial Way, Watford Hertfordshire,
WD24 4TS, UK
Tel:(44)-01923-239668 Fax:(44)-01923-248815

Directive: 2006/42/EC Machinery Directive
The above product has been evaluated for conformity with above directives using the following European standards. The technical construction file (TCF) for this product is retained at the above manufacturer's location.

Machinery Directive: EN ISO12100:2010, EN ISO11148-7:2012, others
Sound Pressure/Power Level: EN ISO15744:2008, EN ISO4871:1996
Vibration Level: EN ISO20643:2008

Signature: _____

Date/Place: _____ /Tokyo, Japan

Name: _____

Title: GENERAL MANAGER MACHINE TOOLS DIV.

NITTO KOHKI Co., Ltd.
2-9-4, Nakaikegami, Ohta-ku, Tokyo, 146-8555, Japan

Being the responsible person appointed and employed the manufacturer.

TQ14180-0